

NOTES:

- 3 A. BACKFLOW TEST RESULTS MUST BE SUBMITTED TO CROSS CONNECTION WITHIN 24 HOURS OF WATER BEING TURNED ON.

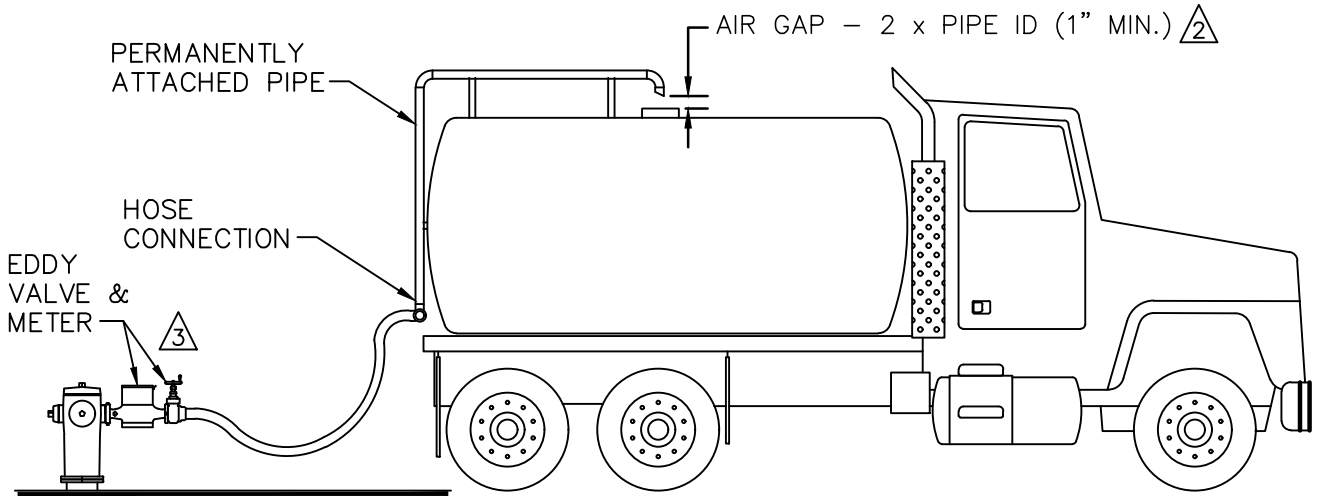

WITH AIR GAP

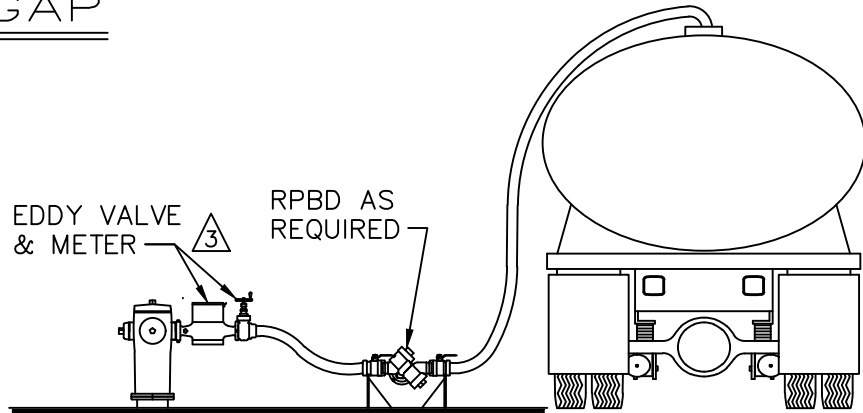

WITH PORTABLE ASSEMBLY

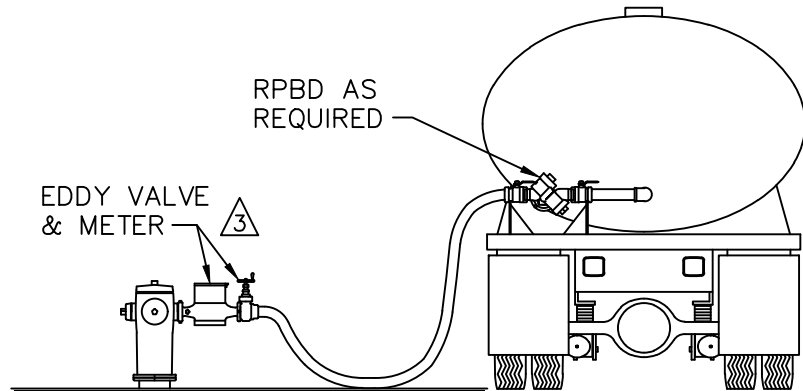

WITH TRUCK MOUNTED ASSEMBLY

CITY OF VICTORVILLE - ENGINEERING DEPARTMENT			<b>3" FIRE HYDRANT METER</b>		<b>W-40</b>
REV.	DATE	BY	<b>WITH WATER METER</b> 3		
3	6/28/18	STAFF	BRIAN W. GENGLER, CITY ENGINEER		
2	12/18/14	STAFF			
1	8/20/08	STAFF			
					SHEET 1 OF 1