

SHED FRAMING DETAIL

*THIS PLAN IS FOR INFORMATIONAL PURPOSES

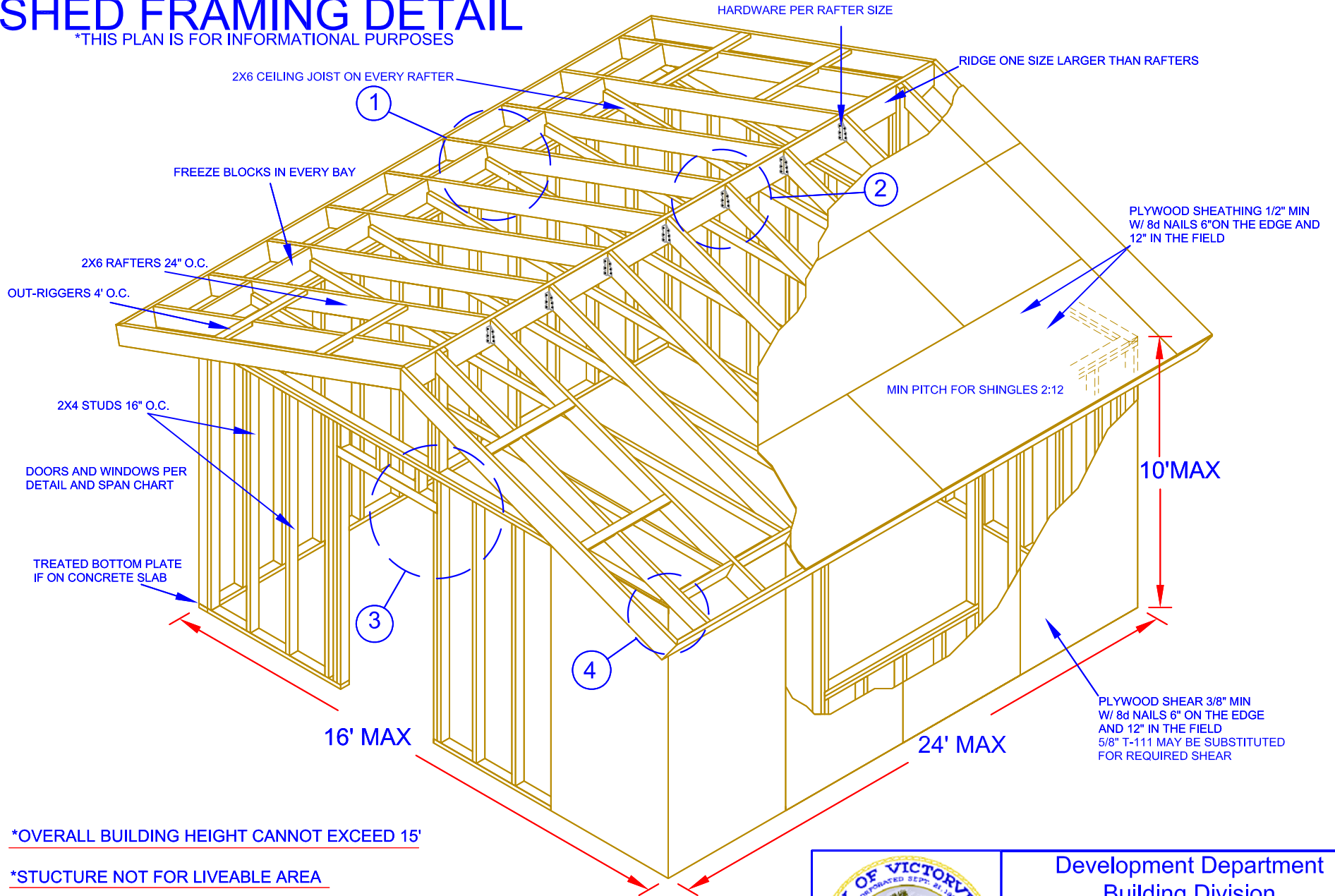

*OVERALL BUILDING HEIGHT CANNOT EXCEED 15'

*STRUCTURE NOT FOR LIVEABLE AREA

*PORTABLE STORAGE SHED ONLY
STRUCTURE NOT TO BE USED AS A GARAGE

*SHEAR OVER ENTIRE EXTERIOR OF SHED

*PLAN SHALL INCLUDE A SEPARATE FOUNDATION PLAN AND FULLY DIMENSIONAL PLOT PLAN



Development Department
Building Division

SHED FRAMING DETAIL

14343 Civic Drive
Victorville, CA 92393

(760) 955-5100
Fax (760) 245-0073

5/22/07
JSM

SHED FRAMING DETAIL

1

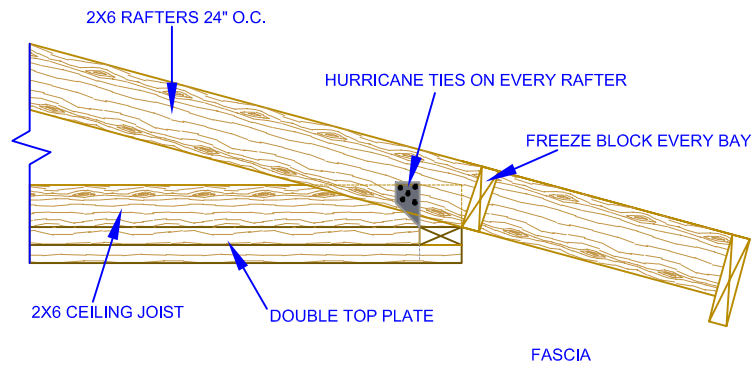

2

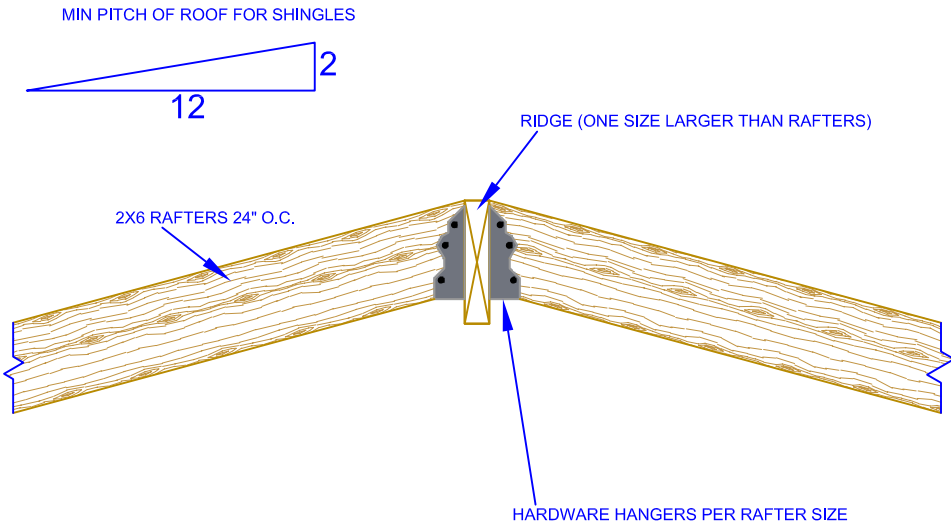

3

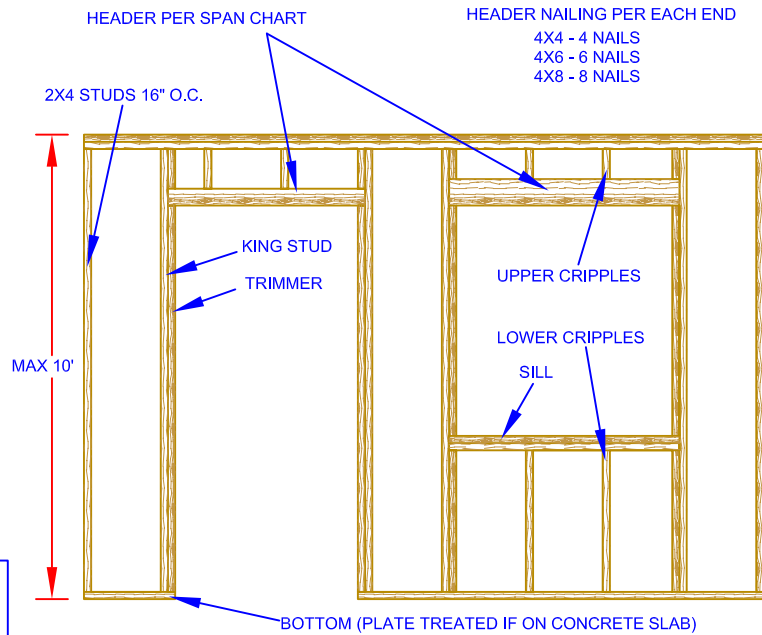

4

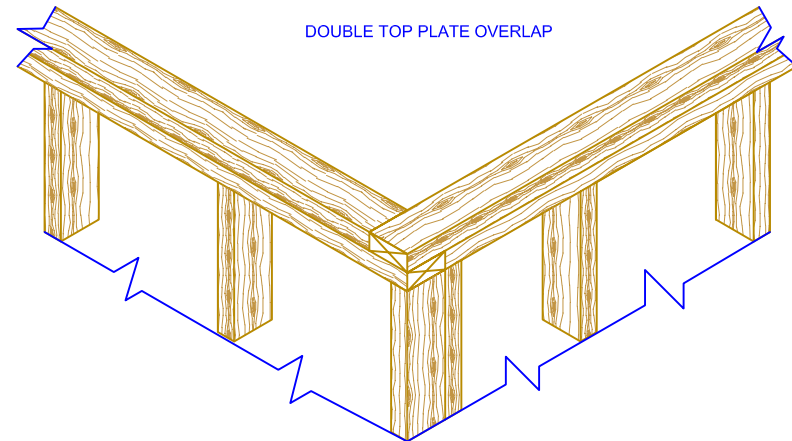

Development Department
 Building Division

SHED FRAMING DETAIL

14343 Civic Drive
 Victorville, CA 92393

(760) 955-5100
 Fax (760) 245-0073

5/22/07
 JSM