



October 19, 2022

Project No. 22124-01

Mr. Craig Wilde
Industrial Property Group, Inc.
10515 20th Street Southeast
Lake Stevens, Washington 98258

Subject: Preliminary Geotechnical Evaluation, Proposed Industrial Development, Northwest of the Intersection of Mojave Drive & Onyx Road, Victorville, California

In accordance with your request, LGC Geotechnical, Inc. has performed a preliminary geotechnical evaluation for the proposed industrial development to be located northwest of the intersection of Mojave Drive and Onyx Road in the City of Victorville, California. The purpose of our study was to evaluate the existing onsite geotechnical conditions and to provide preliminary geotechnical recommendations relative to the proposed development.

Should you have any questions regarding this report, please do not hesitate to contact our office. We appreciate this opportunity to be of service.

Respectfully,

LGC Geotechnical, Inc.

A handwritten signature in blue ink, appearing to read "Brad Zellmer".

Brad Zellmer, GE 2618
Project Engineer



A handwritten signature in blue ink, appearing to read "Kevin B. Colson".

Kevin B. Colson, CEG 2210
Vice President



KBC/BTZ/CPM/amm

Distribution: (5) Addressee (4 wet-signed copies and 1 electronic copy)

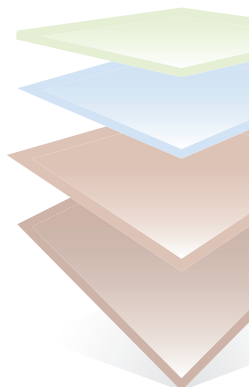

TABLE OF CONTENTS

<u>Section</u>	<u>Page</u>
1.0 INTRODUCTION.....	1
1.1 Project Description and Background.....	1
1.2 Subsurface Exploration.....	1
1.3 Field Percolation Testing.....	2
1.4 Laboratory Testing.....	3
2.0 GEOTECHNICAL CONDITIONS.....	4
2.1 Regional and Local Geology.....	4
2.2 Site-Specific Geology & Generalized Subsurface Conditions.....	4
2.2.1 Quaternary Alluvium (Map Symbol – Qa).....	5
2.3 Geologic Structure.....	5
2.4 Landslides.....	5
2.5 Groundwater.....	5
2.6 Faulting.....	5
2.6.1 Lurching and Shallow Ground Rupture.....	6
2.6.2 Liquefaction and Dynamic Settlement.....	7
2.6.3 Lateral Spreading.....	7
2.6.4 Tsunamis and Seiches.....	7
2.7 Seismic Design Parameters.....	7
2.8 Subsidence.....	9
2.9 Rippability.....	9
2.10 Oversized Material.....	9
2.11 Expansion Potential.....	9
3.0 FINDINGS AND CONCLUSIONS.....	10
4.0 RECOMMENDATIONS.....	11
4.1 Site Earthwork.....	11
4.1.1 Site Preparation.....	11
4.1.2 Removal Depths and Limits.....	12
4.1.3 Temporary Excavations.....	12
4.1.4 Removal Bottoms and Subgrade Preparation.....	13
4.1.5 Material for Fill.....	13
4.1.6 Fill Placement and Compaction.....	14
4.1.7 Trench and Retaining Wall Backfill and Compaction.....	15
4.1.8 Shrinkage and Subsidence.....	15
4.2 Preliminary Foundation Recommendations.....	16
4.2.1 Slab Design and Construction.....	16
4.2.2 Shallow Foundation Maintenance.....	17
4.3 Soil Bearing and Lateral Resistance.....	17
4.4 Lateral Earth Pressures for Retaining Walls.....	18
4.5 Preliminary Pavement Sections.....	20
4.6 Soil Corrosivity.....	21

TABLE OF CONTENTS cont'd

4.7	Nonstructural Concrete Flatwork	21
4.8	Surface Drainage and Landscaping.....	22
4.8.1	General	22
4.8.2	Precise Grading.....	23
4.8.3	Landscaping	23
4.9	Subsurface Water Infiltration	24
4.10	Pre-Construction Documentation and Construction Monitoring.....	26
4.11	Geotechnical Plan Review	26
4.12	Geotechnical Observation and Testing During Construction	26
5.0	LIMITATIONS.....	28

LIST OF TABLES, ILLUSTRATIONS, & APPENDICES

Tables

Table 1 – Summary of Field Infiltration Testing (Page 2)
Table 2 – Seismic Design Parameters (Page 8)
Table 3 – Allowable Soil Bearing Pressures (Page 18)
Table 4 – Lateral Earth Pressures – Select Sandy Backfill (Page 19)
Table 5 – Preliminary Asphalt Concrete Paving Section Options (Page 20)
Table 6 – Nonstructural Concrete Flatwork for Very Low/Low Expansion Potential (Page 22)
Table 7 – Geotechnical Factors of Safety for Design Infiltration Rate (Page 25)

Figures

Figure 1 – Site Location Map (Rear of Text)
Figure 2 – Geotechnical Site Map (Rear of Text)
Figure 3 – Retaining Wall Backfill Detail (Rear of Text)

Appendices

Appendix A – References
Appendix B – Boring Logs
Appendix C – Laboratory Test Results
Appendix D – Infiltration Testing
Appendix E – General Earthwork and Grading Specifications

1.0 INTRODUCTION

LGC Geotechnical has performed a geotechnical evaluation for the proposed industrial development to be located northwest of the intersection of Mojave Drive and Onyx Road, in the City of Victorville, San Bernardino County, California. (Figure 1). This report summarizes our findings, conclusions, and preliminary geotechnical recommendations relative to the proposed development.

1.1 Project Description and Background

The approximately 65-acre, generally rectangular-shaped site is bound on the south by Mojave Drive, on the north by Cactus Road, on the east by Onyx Road, and on the west by Mesa Linda Avenue. During our site review Mojave Drive was a paved road, while the other roads were unimproved dirt roads. At the time of our field visit the site consisted of vacant land with a few man-made dirt trails. Vegetation generally consisted of low scrub and weeds scattered across the site. The majority of the site is relatively flat with topographic relief on the order of approximately 25 to 30 feet. Drainage is toward the northeast generally via sheet flow.

We understand that the proposed site will include one approximately 1,078,880 square foot industrial building, a stormwater quality detention basin in the northeastern portion of the site, and associated parking (HPA Architecture, 2022). Grading plans were not available. It is anticipated that relatively minor cuts and fills are proposed for the building pad. Preliminary building (dead plus live) loads were not provided at the time of this report. The assumed maximum column and wall structural (dead plus live) loads are 125 kips and 10 kips per lineal foot, respectively.

The recommendations given in this report are based on assumptions as indicated above. LGC Geotechnical should be provided with any updated project information, plans and/or any structural loads when they become available, in order to either confirm or modify the recommendations provided herein.

1.2 Subsurface Exploration

In September of 2022, LGC Geotechnical performed a subsurface geotechnical evaluation of the subject site consisting of the excavation of fourteen hollow-stem auger borings in order to evaluate onsite geotechnical conditions.

Fourteen borings (HS-1 through HS-12 and I-1 through I-2) were excavated using a truck-mounted drill rig equipped with 6-inch and 8-inch-diameter hollow-stem augers to depths ranging from approximately 10 to 50 feet below existing grade. An LGC Geotechnical representative observed the drilling operations, logged the borings, and collected soil samples for laboratory testing. Driven soil samples were collected by means of the Standard Penetration Test (SPT) and Modified California Drive (MCD) sampler. The SPT sampler (1.4-inch ID) and MCD sampler (2.4-inch ID, 3.0-inch OD) were driven using a 140-pound hammer falling 30 inches to advance the sampler a total depth of 18 inches or until refusal. The raw blow counts for each 6-inch increment of penetration were recorded on the boring logs. Bulk samples were also collected and logged for laboratory testing at select depths. In select borings, after removal of the

augers the depth of the boring due to caving was measured and is noted on the boring logs. The borings were backfilled with cuttings. The approximate locations of our subsurface explorations are provided on our Geotechnical Map (Figure 2). The boring logs are provided in Appendix B.

At the completion of excavation of Infiltration Borings, I-1 through I-2, an infiltration well was constructed within each boring for testing as outlined in the “Field Percolation Testing” Section below. At the completion of infiltration testing, the installed pipe was removed, and the resulting void backfilled with native soils.

Please note that some settlement of the backfill may occur over time and the excavations should be topped off as needed.

1.3 Field Percolation Testing

Two field percolation tests (I-1 through I-2) were performed in the approximate locations indicated on our Geotechnical Map (Figure 2). Estimation of infiltration rates was accomplished in general accordance with the guidelines set forth by the County of San Bernardino (2013). A 3-inch diameter perforated PVC pipe was placed in the borehole, and the annulus was backfilled with gravel, including placement of approximately 2 inches of gravel at the bottom of the borehole. The infiltration wells were pre-soaked the day prior to testing. During the pre-test, if the water level drops more than 6 inches in 25 minutes for two consecutive readings, the test procedure for coarse-grained soils should be followed. If the water level does not meet that criterion, the procedure for fine-grained soils should be followed. The procedure for coarse-grained soils requires performing the test for one hour and taking one reading every 10 minutes from a fixed reference point. The procedure for fine-grained soils requires performing the test for six hours and taking one reading every 30 minutes from a fixed reference point. The pre-tests indicated the procedure for coarse-grained soils should be followed. The calculated (observed) infiltration is normalized relative to the three-dimensional flow that occurs within the field test to a one-dimensional flow out of the bottom of the boring only (i.e., “Porchet Method”). The observed infiltration rates are provided in Table 1 below and do not include any factors of safety.

TABLE 1

Summary of Field Infiltration Testing

Infiltration Test Location	Infiltration Test Approximate Depth (ft)	Observed Infiltration Rate (inch/hr.) *
I-1	10	6.9
I-2	10	4.5

*Does not include a factor of safety

It should also be emphasized that infiltration test results are only representative of the location and depth where they are performed. Varying subsurface conditions may exist outside of the test locations which could alter the calculated infiltration rates indicated above. The percolation tests were performed using relatively clean water free of particulates, silt, etc. Field percolation test data is attached. Infiltration test data is presented in Appendix D. Refer to further discussion in Section 4.9.

1.4 Laboratory Testing

Representative bulk and driven samples were obtained for laboratory testing during our field evaluation. Laboratory testing included in-situ moisture content and dry density, Atterberg Limits, gradation/fines content, consolidation, expansion index, laboratory compaction, R-Value, and corrosion characteristics (sulfate, chloride, pH and minimum resistivity).

- Dry density of the samples collected ranged from approximately 102 pounds per cubic foot (pcf) to 130 pcf, with an average of approximately 115 pcf. Field moisture contents ranged from approximately 1 percent to 17 percent, with an average of approximately 4 percent.
- One Atterberg Limit (liquid limit and plastic limit) test was performed. Results indicated a Plasticity Index of 7.
- Five sieve analysis and four fines content tests indicated a fines content (passing No. 200 sieve) ranging from approximately 24 to 49 percent. Based on the Unified Soils Classification System (USCS), the tested samples are classified as “coarse-grained.”
- Two Expansion Index (EI) tests indicated EI values of 0 to 18, corresponding to “Very Low” expansion potential.
- Four Consolidation tests were performed. The deformation versus vertical stress plots is provided in Appendix C.
- One laboratory compaction curve resulted in a maximum dry density value of 129.5 pcf with an optimum moisture content value of 9.0 percent.
- One R-Value test was performed and indicated a result of 27.
- Corrosion testing indicated soluble sulfate contents less than approximately 0.02 percent, a chloride content of 21 parts per million (ppm), pH of 8.6, and a minimum resistivity of 2,590 ohm-centimeters.

A summary of the results is presented in Appendix C. The moisture and dry density test results are presented on the boring logs in Appendix B.

2.0 GEOTECHNICAL CONDITIONS

2.1 Regional and Local Geology

Regionally the site is located in the southwestern portion of the Mojave Desert Geomorphic Province of California. The following discussion regarding the Geomorphic Province is from the California Geological Survey Note 36 (CGS, 2002). The Mojave Desert is a broad interior region of isolated mountain ranges separated by expanses of desert plains. It has an interior enclosed drainage and many playas. There are two important fault trends that control topography: a prominent northwest-southeast trend and a secondary east-west trend, which is in apparent alignment with the Transverse Ranges Geomorphic Province on the southwestern side of the Mojave Desert. The Mojave Province is wedged in a sharp angle between the Garlock Fault which is the southern boundary of the Sierra Nevada Province, and the San Andreas Fault where it bends east from its northwest trend. The northern boundary of the Mojave is separated from the prominent Basin and Range Province by the eastern extension of the Garlock Fault. The site is located southeast of the Garlock Fault and north of the San Andreas Fault.

Locally, the site is located on a broad, nearly flat alluvial plain. The alluvium is derived from the nearby hills and mountains. The northward-flowing Mojave River is located approximately 4 miles northeast of the site and drainage in the vicinity of the site is generally via sheet flow towards the northeast. Old alluvial deposits are located in the upper reaches of incised drainages along the banks of the river. The alluvial plain is underlain at depth by granitic and metasedimentary rocks of the San Bernardino Mountain assemblage, and steep rugged hillsides that expose these rocks are located approximately 5 to 8 miles northeast and northwest of the site, respectively (Dibblee, 2008). A large playa (dry lakebed), known as El Mirage Dry Lake, is located adjacent to the hillsides northwest of the site.

2.2 Site-Specific Geology & Generalized Subsurface Conditions

Based on our review of regional geologic mapping in the vicinity of the site (Dibblee, 2008) and our site visit, the project area is underlain by Quaternary alluvial deposits. A brief description of the geologic unit encountered is presented below.

As encountered in our subsurface evaluation (borings), site materials primarily consist of medium dense to very dense silty sands and very stiff to hard sandy silts to the maximum explored depth of approximately 50 feet below existing grade. Moisture contents in the upper approximate 5 feet are generally well below optimum.

It should be noted that our excavations are only representative of the location and time where/when they are performed, and varying subsurface conditions may exist outside of the performed location. In addition, subsurface conditions can change over time. The soil descriptions provided above should not be construed to mean that the subsurface profile is uniform, and that soil is homogeneous within the project area. For details on the stratigraphy at the exploration locations, refer to Appendix B.

2.2.1 Quaternary Alluvium (Map Symbol - Qa)

Quaternary alluvial deposits were exposed at the surface and were encountered to the maximum depth explored, approximately 50 feet below the ground surface. The alluvium was found to consist mostly of silty sand and sandy silt with scattered discontinuous beds of sandy clay and clayey sand, and scattered carbonate (caliche) deposits in the upper approximately 10 feet.

2.3 Geologic Structure

Geologic structure was not identified in the subject site geotechnical evaluation. The alluvial materials encountered are generally massive, and bedding (if present) is assumed to be nearly horizontal.

2.4 Landslides

The topography of the site and surrounding area is generally flat. Our research and field observations do not indicate the presence of landslides on the site or in the immediate vicinity. Review of regional geologic maps of the area do not indicate the presence of known or suspected landslides in the vicinity of the site. Therefore, the possibility of landslides at the site is considered nil.

2.5 Groundwater

Groundwater was not encountered during our subsurface field evaluation to the maximum explored depth of approximately 50 feet below existing ground surface. Historic high groundwater is anticipated to be greater than 50 feet below existing grade. The California Department of Water Resources Water Data Library (CDWR, 2022) indicates several wells existed within approximately 2-miles of the site; however, the wells were not frequently monitored. Based on the data, it appears that groundwater between the 1950's and 1990's has lowered from between approximately 160 to approximately 300 feet deep, and since the 2000's it has been deeper than 300 feet deep.

Seasonal fluctuations of groundwater elevations should be expected over time. In general, groundwater levels fluctuate with the seasons and local zones of perched groundwater may be present within the near-surface deposits due to local seepage or during rainy seasons. Groundwater conditions below the site may be variable, depending on numerous factors including seasonal rainfall, local irrigation and groundwater pumping, among others.

2.6 Faulting

California is located on the boundary between the Pacific and North American Lithospheric Plates. The average motion along this boundary is on the order of 50-mm/yr. in a right-lateral sense. The majority of the motion is expressed at the surface along the northwest trending San Andreas Fault Zone with lesser amounts of motion accommodated by sub-parallel faults

located predominantly west of the San Andreas including the San Jacinto, Elsinore, Newport-Inglewood, Rose Canyon, and Coronado Bank Faults. Within Southern California, a large bend in the San Andreas Fault north of the San Gabriel Mountains has resulted in a transfer of a portion of the right-lateral motion between the plates into left-lateral displacement and vertical uplift. Compression south and west of the bend has resulted in folding, left-lateral, reverse thrust faulting, and regional uplift creating the east-west trending Transverse Ranges and several east-west trending faults. Further south within the Los Angeles Basin, “blind thrust” faults are believed to have developed below the surface also as a result of this compression, which have resulted in earthquakes such as the 1994 Northridge event along faults with little to no surface expression.

Prompted by damaging earthquakes in Northern and Southern California, State legislation and policies concerning the classification and land-use criteria associated with faults have been developed. The Alquist-Priolo Earthquake Fault Zoning Act was implemented in 1972 to prevent the construction of urban developments across the trace of active faults. California Geologic Survey Special Publication 42 was created to provide guidance for following and implementing the law requirements. Special Publication 42 was most recently revised in 2018 (CGS, 2018). According to the State Geologist, a “Holocene-active” fault is defined as one which has had surface displacement within Holocene time (roughly the last 11,700 years). Regulatory Earthquake Fault Zones have been delineated to encompass traces of known, Holocene-active faults to address hazards associated with surface fault rupture within California. Where developments for human occupation are proposed within these zones, the state requires detailed fault evaluations be performed so that engineering-geologists can identify the locations of active faults and recommend setbacks from locations of possible surface fault rupture.

The subject site is not located within a State of California Fault Rupture Hazard Zone (CGS, 2018 and 2022). The nearest Holocene-active faults identified by CGS are the Helendale Fault, located approximately 14.5 miles northeast of the site and the San Andreas Fault Zone located approximately 18 miles to the southwest of the site. These faults trend northwest-southeast, oblique to the site and not toward the site. Therefore, the possibility of damage due to ground rupture is considered low since no active faults are known to cross the site.

Secondary effects of seismic shaking resulting from large earthquakes on the major faults in the Southern California region, which may affect the site, include ground lurching and shallow ground rupture, soil liquefaction, dynamic settlement, seiches and tsunamis. These secondary effects of seismic shaking are a possibility throughout the Southern California region and are dependent on the distance between the site and causative fault, and the onsite geology. A discussion of these secondary effects is provided in the following sections.

2.6.1 Lurching and Shallow Ground Rupture

Soil lurching refers to the rolling motion on the ground surface by the passage of seismic surface waves. Effects of this nature are not likely to be significant where the thickness of soft sediments do not vary appreciably under structures. Ground rupture due to active faulting is not likely to occur onsite due to the absence of known active fault traces. Ground cracking due to shaking from distant seismic events is not considered a significant hazard, although it is a possibility at any site.

2.6.2 Liquefaction and Dynamic Settlement

Liquefaction is a seismic phenomenon in which loose, saturated, granular soils behave similarly to a fluid when subject to high-intensity ground shaking. Liquefaction occurs when three general conditions coexist: 1) shallow groundwater; 2) low density non-cohesive (granular) soils; and 3) high-intensity ground motion. Studies indicate that saturated, loose near-surface cohesionless soils exhibit the highest liquefaction potential, while dry, dense, cohesionless soils and cohesive soils exhibit low to negligible liquefaction potential. In general, cohesive soils are not considered susceptible to liquefaction, depending on their plasticity and moisture content. Effects of liquefaction on level ground include settlement, sand boils, and bearing capacity failures below structures. Dynamic settlement of dry loose sands can occur as the sand particles tend to settle and densify as a result of a seismic event.

Due to the depth of groundwater greater than 50 feet, the generally dense/hard nature of underlying soils, the potential for liquefaction and liquefaction-induced settlement is considered very low.

2.6.3 Lateral Spreading

Lateral spreading is a type of liquefaction-induced ground failure associated with the lateral displacement of surficial blocks of sediment resulting from liquefaction in a subsurface layer. Once liquefaction transforms the subsurface layer into a fluid mass, gravity plus the earthquake inertial forces may cause the mass to move down-slope towards a free face (such as a river channel or an embankment). Lateral spreading may cause large horizontal displacements and such movement typically damages pipelines, utilities, bridges, and structures.

Due to the very low potential for liquefaction, the potential for lateral spreading is also considered very low.

2.6.4 Tsunamis and Seiches

Based on the elevation of the site, with respect to sea level, the possibility of damage to the site during a large tsunami event is considered nil. There are no nearby large, enclosed bodies of water, therefore the possibility of damage due to a seiche is nil.

2.7 Seismic Design Parameters

The site seismic characteristics were evaluated per the guidelines set forth in Chapter 16, Section 1613 of the 2019 California Building Code (CBC) and applicable portions of ASCE 7-16 which has been adopted by the CBC. Please note that the following seismic parameters are only applicable for code-based acceleration response spectra and are not applicable for where site-specific ground motion procedures are required by ASCE 7-16. Representative site coordinates of latitude 34.5289 degrees north and longitude -117.3905 degrees west were utilized in our analyses. The maximum considered earthquake (MCE) spectral response accelerations (S_{MS} and

S_{M1}) and adjusted design spectral response acceleration parameters (S_{DS} and S_{D1}) for Site Class C are provided in Table 2 below. The structural designer should contact the geotechnical consultant if structural conditions (e.g., number of stories, seismically isolated structures, etc.) require site-specific ground motions.

TABLE 2

Seismic Design Parameters

Selected Parameters from 2019 CBC, Section 1613 - Earthquake Loads	Seismic Design Values	Notes/Exceptions
Distance to applicable faults classifies the site as a "Near-Fault" site.		Section 11.4.1 of ASCE 7
Site Class	C	Chapter 20 of ASCE 7
S_s (Risk-Targeted Spectral Acceleration for Short Periods)	1.191g	From SEAOC, 2021
S_1 (Risk-Targeted Spectral Accelerations for 1-Second Periods)	0.463g	From SEAOC, 2021
F_a (per Table 1613.2.3(1))	1.2	For Simplified Design Procedure of Section 12.14 of ASCE 7, F_a shall be taken as 1.4 (Section 12.14.8.1)
F_v (per Table 1613.2.3(2))	1.5	-
S_{MS} for Site Class C [Note: $S_{MS} = F_a S_s$]	1.429g	-
S_{M1} for Site Class C [Note: $S_{M1} = F_v S_1$]	0.695g	-
S_{DS} for Site Class C [Note: $S_{DS} = (2/3) S_{MS}$]	0.953g	-
S_{D1} for Site Class C [Note: $S_{D1} = (2/3) S_{M1}$]	0.463g	-
C_{RS} (Mapped Risk Coefficient at 0.2 sec)	0.935	ASCE 7 Chapter 22
C_{R1} (Mapped Risk Coefficient at 1 sec)	0.918	ASCE 7 Chapter 22

A deaggregation of the PGA based on a 2,475-year average return period (MCE) indicates that an earthquake magnitude of 7.1 at a distance of approximately 21 km from the site would contribute the most to this ground motion. A deaggregation of the PGA based on a 475-year average return period (Design Earthquake) indicates that an earthquake magnitude of 7.1 at a distance of approximately 24 km from the site would contribute the most to this ground motion (USGS, 2014).

Section 1803.5.12 of the 2019 CBC (per Section 11.8.3 of ASCE 7) states that the maximum considered earthquake geometric mean (MCE_G) Peak Ground Acceleration (PGA) should be used for liquefaction potential. The PGA_M for the site is equal to 0.60g (SEAOC, 2022). The design PGA is equal to 0.40g ($2/3$ of PGA_M).

2.8 Subsidence

Subsidence is the settlement of the ground surface over large areas (typically on the order of square miles) typically due to the lowering of the groundwater table. Mitigation against such a large-scale groundwater drawdown cannot be performed on a site-specific level, but instead “requires regional cooperation among numerous agencies” and therefore is not a site-specific geotechnical consideration. The soils encountered in our field evaluation did not indicate the presence of soils susceptible to collapse or excessive settlement. Based on the local site geologic conditions, the potential for subsidence in the site development area is considered low.

2.9 Rippability

In general, excavation for foundations and underground improvements should be achievable with the appropriate earthwork equipment.

2.10 Oversized Material

Encountering significant quantities of oversized material (material larger than 8 inches in maximum dimension) is not anticipated during grading. Recommendations are provided for appropriate handling of oversized materials, if encountered, in Appendix E. If feasible, crushing oversized materials or exporting to an offsite location may be considered.

2.11 Expansion Potential

Based on the results of laboratory testing, site soils are anticipated to have a “Very Low” expansion potential. Final expansion potential of site soils should be determined at the completion of grading. Results of expansion testing at finish grades will be utilized to confirm final foundation design.

3.0 FINDINGS AND CONCLUSIONS

Based on the results of our geotechnical evaluation, it is our opinion that the proposed site development is feasible from a geotechnical standpoint, provided the following conclusions and recommendations are incorporated into the site design, grading, and construction.

The following is a summary of the primary geotechnical factors, which may affect future development of the site.

- In general, our subsurface evaluation primarily indicates that the site contains medium dense to very dense silty sands and medium stiff to hard sandy silts to the maximum explored depth of approximately 50 feet below existing grade. Moisture content of soils in the upper approximate 5 feet are generally well below optimum. The near-surface compressible soils are not suitable for the planned improvements in their present condition (refer to Section 4.1).
- From a geotechnical perspective, onsite soils are anticipated to be suitable for use as general compacted fill, provided they are screened of construction debris and any oversized material (8 inches in greatest dimension). Significant moisture conditioning of site soils should be anticipated to achieve adequate compaction.
- Groundwater was not encountered to the maximum explored depth of approximately 50 feet below existing ground surface. Historic high groundwater is anticipated to be greater than 50 feet below existing ground surface (CDWR, 2022).
- The subject site is not located within an Alquist-Priolo Earthquake Fault Zone. No active faults are mapped on the site. No faults were identified on the site during our site evaluation. The proposed development will likely be subjected to strong seismic ground shaking during its design life from one of the regional faults.
- Due to a lack of groundwater in the upper 50 feet and the generally dense/hard on underlying native soils, the potential for liquefaction and liquefaction-induced settlement is considered very low.
- Based on laboratory testing, soils exposed at the proposed foundation level are anticipated to have a "Very Low" expansion potential (EI not exceeding 20). This shall be confirmed at the completion of site earthwork.
- Excavation for foundations and underground improvements should be achievable with the appropriate earthwork equipment.
- The field infiltration tests indicated observed infiltration rates of 6.9 inch/hour and 4.5 inch/hour for I-1 and I-2, respectively. These values do not include any factor of safety. Recommendations are provided in Section 4.9.
- The site contains soils with high fines content (i.e., silts and clay) that are not suitable for backfill of retaining walls. Therefore, select grading and stockpiling of native suitable sandy soils and/or import of select sandy soils meeting project recommendations will be required for retaining wall backfill.

4.0 RECOMMENDATIONS

The following recommendations are to be considered preliminary and should be confirmed upon completion of earthwork operations. In addition, they should be considered minimal from a geotechnical viewpoint, as there may be more restrictive requirements from the architect, structural engineer, building codes, governing agencies, or the City. It is the responsibility of the builder to ensure these recommendations are provided to the appropriate parties.

It should be noted that the following geotechnical recommendations are intended to provide sufficient information to develop the site in general accordance with the 2019 California Building Code (CBC) requirements. With regard to the potential occurrence of potentially catastrophic geotechnical hazards such as fault rupture, earthquake-induced landslides, liquefaction, etc. the following geotechnical recommendations should provide adequate protection for the proposed development to the extent required to reduce seismic risk to an “acceptable level.” The “acceptable level” of risk is defined by the California Code of Regulations as “the level that provides reasonable protection of the public safety, though it does not necessarily ensure continued structural integrity and functionality of the project” [Section 3721(a)]. Therefore, repair and remedial work of the proposed improvement may be required after a significant seismic event. With regards to the potential for less significant geologic hazards to the proposed development, the recommendations contained herein are intended as a reasonable protection against the potential damaging effects of geotechnical phenomena such as expansive soils, fill settlement, groundwater seepage, etc. It should be understood, however, that although our recommendations are intended to maintain the structural integrity of the proposed development and structures given the site geotechnical conditions, they cannot preclude the potential for some cosmetic distress or nuisance issues to develop as a result of the site geotechnical conditions.

The geotechnical recommendations contained herein must be confirmed to be suitable or modified based on the actual exposed conditions.

4.1 Site Earthwork

We anticipate that earthwork at the site will consist of required earthwork removals, foundation construction and utility line construction and backfill. We recommend that earthwork onsite be performed in accordance with the following recommendations, the City of Victorville, 2019 CBC and the General Earthwork and Grading Specifications included in Appendix E. In case of conflict, the following recommendations shall supersede previous recommendations and those included as part of Appendix E.

4.1.1 Site Preparation

Prior to grading of areas to receive structural fill, engineered structures or improvements should be demolished and the area should be cleared of existing vegetation (shrubs, trees, grass, etc.), surface obstructions, existing debris and potentially compressible or otherwise unsuitable material. Debris should be removed and properly disposed of off-site. Holes resulting from the removal of buried obstructions, which extend below proposed removal bottoms, should be replaced with suitable compacted fill material. Any

abandoned utility lines should be completely removed and replaced with properly compacted fill.

If cesspools or septic systems are encountered, they should be removed in their entirety. The resulting excavation should be backfilled with properly compacted fill soils. As an alternative, cesspools can be backfilled with lean sand-cement slurry. Any encountered wells should be properly abandoned in accordance with regulatory requirements. At the conclusion of the clearing operations, a representative of LGC Geotechnical should observe and accept the site prior to further grading.

4.1.2 Removal Depths and Limits

In order to provide a relatively uniform bearing condition for the planned improvements, upper loose/compressible native soils are to be removed and replaced as properly compacted fills. For preliminary planning purposes, the depth of required removals may be estimated as indicated below.

Building Structure: Removals should extend a minimum depth of 5 feet below existing grade or 2 feet below the proposed footings, whichever is greater. In general, the envelope for removals should extend laterally a minimum horizontal distance equal to the fill thickness so that a 1:1 plane may be projected from the footing to the edge of the removal, with a minimum lateral extent of 5 feet beyond the edges of the proposed building footprint. The removals for loading dock areas, which act as retaining walls, should extend a minimum of 2 feet below the bottom of the proposed footings, which is likely deeper than 5 feet below existing grade, depending upon the design of the loading docks.

Retaining/Free-Standing Wall Structures: Removals should extend a minimum of 3 feet below existing grade, or 1-foot below proposed footings, whichever is greater.

Pavement and Hardscape Areas: Removals should extend to a depth of at least 2 feet below the existing grade. Removals in any design cut areas of the pavement may be reduced by the depth of the design cut but should not be less than 1-foot below the finished subgrade (i.e., below planned aggregate base/asphalt concrete). In general, the envelope for removals should extend laterally a minimum lateral distance of 2 feet beyond the edges of the proposed improvements.

Local conditions may be encountered during excavation that could require additional over-excavation beyond the above-noted minimum in order to obtain an acceptable subgrade including localized areas of undocumented fill. The actual depths and lateral extents of grading will be determined by the geotechnical consultant, based on subsurface conditions encountered during grading. Removal areas should be accurately staked in the field by the Project Surveyor.

4.1.3 Temporary Excavations

Temporary excavations should be performed in accordance with project plans,

specifications, and applicable Occupational Safety and Health Administration (OSHA) requirements. Excavations should be laid back or shored in accordance with OSHA requirements before personnel or equipment are allowed to enter. Based on our field investigation, the majority of site soils are anticipated to be OSHA Type “C” soils (refer to the attached boring logs). Sandy soils are present and should be considered susceptible to caving. Soil conditions should be regularly evaluated during construction to verify conditions are as anticipated. The contractor shall be responsible for providing the “competent person” required by OSHA standards to evaluate soil conditions. Close coordination with the geotechnical consultant should be maintained to facilitate construction while providing safe excavations. Excavation safety is the sole responsibility of the contractor.

Vehicular traffic, stockpiles, and equipment storage should be set back from the perimeter of excavations a minimum distance equivalent to a 1:1 projection from the bottom of the excavation or 5 feet, whichever is greater. Once an excavation has been initiated, it should be backfilled as soon as practical. Prolonged exposure of temporary excavations may result in some localized instability. Excavations should be planned so that they are not initiated without sufficient time to shore/fill them prior to weekends, holidays, or forecasted rain.

It should be noted that any excavation that extends below a 1:1 (horizontal to vertical) projection of an existing foundation will remove existing support of the structure foundation. If requested, temporary shoring parameters can be provided.

4.1.4 Removal Bottoms and Subgrade Preparation

In general, removal bottom areas and any areas to receive compacted fill should be scarified to a minimum depth of 6 inches, brought to a near-optimum moisture condition, and re-compacted per project recommendations.

Removal bottoms and areas to receive fill should be observed and accepted by the geotechnical consultant prior to subsequent fill placement.

4.1.5 Material for Fill

From a geotechnical perspective, the onsite soils are generally considered suitable for use as general compacted fill (i.e., non-retaining wall backfill), provided they are screened of organic materials, construction debris and any oversized material (8 inches in greatest dimension). Significant moisture conditioning of site soils should be anticipated as outlined in the section below.

From a geotechnical viewpoint, any required import soils should consist of clean, relatively granular soils of Low expansion potential (expansion index 50 or less based on ASTM D4829) and no particles larger than 3 inches in greatest dimension. Source samples of planned importation should be provided to the geotechnical consultant for laboratory testing a minimum of 3 working days prior to any planned importation for required laboratory testing.

Any required retaining wall backfill should consist of sandy soils with a maximum of 35 percent fines (passing the No. 200 sieve) per American Society for Testing and Materials (ASTM) Test Method D1140 (or ASTM D6913/D422) and a Very Low expansion potential (EI of 20 or less per ASTM D4829). Soils should also be screened of organic materials, construction debris and any material greater than 3 inches in maximum dimension. The site contains soils that are not suitable for retaining wall backfill due to their fines content; therefore, select grading and stockpiling and/or import of select sandy soils will be required by the contractor to obtain suitable retaining wall backfill soil.

Aggregate base (crushed aggregate base or crushed miscellaneous base) should conform to the requirements of Section 200-2 of the Standard Specifications for Public Works Construction ("Greenbook") for untreated base materials (except processed miscellaneous base) or Caltrans Class 2 aggregate base.

4.1.6 Fill Placement and Compaction

Material to be placed as fill should be brought to near-optimum moisture content (generally at about 2 percent above optimum moisture content) and recompact to at least 90 percent relative compaction (per ASTM D1557). Significant moisture conditioning of site soils should be anticipated in order to achieve the required degree of compaction. In general, soils will require additional moisture conditioning in order to achieve the required compaction are present. Soils may also be present that will require drying and/or mixing the very moist soils prior to reusing the materials in compacted fills. The optimum lift thickness to produce a uniformly compacted fill will depend on the type and size of compaction equipment used. In general, fill should be placed in uniform lifts not exceeding 8 inches in loose thickness. Each lift should be thoroughly compacted and accepted prior to subsequent lifts. Generally, placement and compaction of fill should be performed in accordance with local grading ordinances and with observation and testing by the geotechnical consultant. Oversized material as previously defined should be removed from site fills.

Fill placed on any slopes greater than 5:1 (horizontal to vertical) should be properly keyed and benched into firm and competent soils as it is placed in lifts. During backfill of excavations, the fill should be properly benched into firm and competent soils of temporary backcut slopes as it is placed in lifts.

Aggregate base material should be compacted to a minimum of 95 percent relative compaction at or slightly above-optimum moisture content per ASTM D1557. Subgrade below aggregate base should be compacted to a minimum of 90 percent relative compaction per ASTM D1557 at or slightly above-optimum moisture content.

If gap-graded ¾-inch rock is used for backfill (around storm drain storage chambers, retaining wall backfill, etc.) it will require compaction. Rock shall be placed in thin lifts (typically not exceeding 6 inches) and mechanically compacted with observation by the geotechnical consultant. Backfill rock shall meet the requirements of ASTM D2321. Gap-graded rock is required to be wrapped in filter fabric to prevent the migration of fines into the rock backfill.

4.1.7 Trench and Retaining Wall Backfill and Compaction

Bedding material used within the pipe zone should conform to the requirements of the current Greenbook and the pipe manufacturer. Where applicable, sand having a sand equivalent (SE) of 30 or greater (per Caltrans Test Method [CTM] 217) may be used to bed and shade the pipes within the bedding zone. Sand backfill should be densified by jetting or flooding and then tamped to ensure adequate compaction. Bedding sand should be from a natural source, manufactured sand from recycled material is not suitable for jetting. The onsite soils may generally be considered suitable as trench backfill (zone defined as 12 inches above the pipe to subgrade), provided the soils are screened of rocks greater than 6 inches in maximum dimension, construction debris and organic material. Trench backfill should be compacted in uniform lifts (as outlined above in Section 4.1.5 "Material for Fill") by mechanical means to at least 90 percent relative compaction (per ASTM D1557). If gap-graded rock is used for trench backfill, refer to Section 4.1.6.

In backfill areas where mechanical compaction of soil backfill is impractical due to space constraints, flowable fill such as sand-cement slurry may be substituted for compacted backfill. The slurry should contain about one sack of cement per cubic yard. When set, such a mix typically has the consistency of compacted soil. Sand cement slurry placed near the surface within landscape areas should be evaluated for potential impacts on planned improvements.

Any required retaining wall backfill should consist of predominately granular, sandy soils outlined in Section 4.1.5. The limits of select sandy backfill should extend at minimum $\frac{1}{2}$ the height of the retaining wall or the width of the heel (if applicable), whichever is greater (Refer to Figure 3). Retaining wall backfill soils should be compacted in relatively uniform thin lifts to a minimum of 90 percent relative compaction (per ASTM D1557). Jetting or flooding of retaining wall backfill materials should not be permitted. If gap-graded rock is used for retaining wall backfill, refer to Section 4.1.6.

A representative from LGC Geotechnical should observe, probe, and test the backfill to verify compliance with the project recommendations.

4.1.8 Shrinkage and Subsidence

Allowance in the earthwork volumes budget should be made for an estimated 5 to 10 percent reduction in volume of near-surface (upper approximate 5 feet) soils. It should be stressed that these values are only estimates and that an actual shrinkage factor would be extremely difficult to predetermine. Subsidence, due to earthwork operations, is expected to be on the order of 0.1-foot. These values are estimates only and exclude losses due to removal of any vegetation or debris. The above shrinkage estimate is intended as an aid for others in determining preliminary earthwork quantities. However, these estimates should be used with some caution since they are not absolute values. The effective shrinkage of onsite soils will depend primarily on the type of compaction equipment and method of compaction used onsite by the contractor and accuracy of the topographic survey.

4.2 Preliminary Foundation Recommendations

The following foundation recommendations are preliminary and must be confirmed by LGC Geotechnical at the completion of project plans (i.e., foundation, grading, etc.) as well as completion of earthwork. Please note that foundation recommendations are based on estimated structural loads. Increase of structural loads may require revision of the provided foundation recommendations and parameters and/or revised remedial recommendations.

Based on preliminary laboratory testing, site soils are anticipated to be of Very Low expansion potential (EI of 20 or less per ASTM D4829). However, this must be verified based on as-graded conditions. Recommended soil bearing and estimated static settlement are provided in Section 4.3. Since site soils are anticipated to be of "Very Low" expansion potential special design considerations from a geotechnical perspective are not anticipated to be required.

4.2.1 Slab Design and Construction

From a geotechnical perspective, minimum slab thicknesses of 6 inches and 4 inches are recommended for new slabs in the warehouse areas and office areas, respectively. Slabs are to be supported on compacted fill soils properly prepared in accordance with the recommendations provided in this report. Actual slab reinforcement and thickness should be determined by the structural engineer based on the imposed loading. Additional slab-on-grade recommendations can be provided for alternative building types upon request.

The foundation designer may use a modulus of vertical subgrade reaction (k) of 150 pounds per cubic inch (pounds per square inch per inch of deflection). This value is for a 1-foot by 1-foot square loaded area and should be adjusted by the structural designer for the area of the proposed footing using the following formula:

$$k = 150 \times [(B+1)/2B]^2$$

k = modulus of vertical subgrade reaction, pounds per cubic inch (pci)

B = foundation width (feet)

It is recommended that subgrade soils below slabs be moisture conditioned in order to maintain the recommended moisture content up to the time of concrete placement. The recommended moisture content of the slab subgrade soils should be between optimum moisture content and approximately 2 percent above optimum moisture content to a minimum depth of 12 inches. The moisture content of the slab subgrade should be verified by the geotechnical consultant within 1 to 2 days prior to concrete placement. In addition, this moisture content should be maintained around the immediate perimeter of the slab during construction and up to occupancy of the building structures.

The following recommendations are for informational purposes only, as they are unrelated to the geotechnical performance of the foundation. The following recommendations may be superseded by the foundation engineer and/or owner. Some post-construction moisture migration should be expected below the foundation. In general, interior floor slabs with moisture sensitive floor coverings should be underlain

by a minimum 10 mil thick polyolefin material vapor retarder, which has a water vapor transmission rate (permeance) of less than 0.03 perms. The need for sand and/or the sand thickness (above and/or below the vapor retarder) should be specified by the structural engineer, architect or concrete contractor. The selection and thickness of sand is not a geotechnical engineering issue and is therefore outside our purview.

4.2.2 Shallow Foundation Maintenance

The geotechnical parameters provided herein assume that if the areas adjacent to the foundation are planted and irrigated, these areas will be designed with proper drainage and adequately maintained so that ponding, which causes significant moisture changes below the foundation, does not occur. Our recommendations do not account for excessive irrigation and/or incorrect landscape design. Plants should only be provided with sufficient irrigation for life and not overwatered to saturate subgrade soils. Sunken planters placed adjacent to the foundation, should either be designed with an efficient drainage system or liners to prevent moisture infiltration below the foundation. Some lifting of the perimeter foundation beam should be expected even with properly constructed planters.

In addition to the factors mentioned above, future owners/property management personnel should be made aware of the potential negative influences of trees and/or other large vegetation. Roots that extend near the vicinity of foundations can cause distress to foundations. Future owners (and the owner's landscape architect) should not plant trees/large shrubs closer to the foundations than a distance equal to half the mature height of the tree or 20 feet, whichever is more conservative unless specifically provided with root barriers to prevent root growth below the building foundation.

It is the owner's responsibility to perform periodic maintenance during hot and dry periods to ensure that adequate watering has been provided to keep soil from separating or pulling back from the foundation. Future owners and property management personnel should be informed and educated regarding the importance of maintaining a constant level of soil-moisture. The owners should be made aware of the potential negative consequences of both excessive watering, as well as allowing potentially expansive soils to become too dry. Expansive soils can undergo shrinkage during drying, and swelling during the rainy winter season, or when irrigation is resumed. This can result in distress to building structures and hardscape improvements. These recommendations should be provided to future owners and property management personnel.

4.3 Soil Bearing and Lateral Resistance

Provided our earthwork recommendations are implemented, the following minimum footing widths and embedments for isolated spread and continuous wall footings are recommended for the corresponding allowable bearing pressures.

TABLE 3

Allowable Soil Bearing Pressures

Allowable Static Bearing Pressure (psf)	Minimum Footing Width (feet)	Minimum Footing Embedment* (feet)
3,000	4	2
2,500	3	2
2,000	2	1.5
1,500	1	1

*Refers to minimum depth to the bottom of the footing below lowest adjacent finish grade.

These allowable bearing pressures are applicable for level (ground slope equal to or flatter than 5 horizontal feet to 1-foot vertical) conditions only. Bearing values indicated above are for total dead loads and live loads. The above vertical bearing may be increased by one-third for short durations of loading which will include the effect of wind or seismic loading. The increase is based on a reduced factor of safety (seismic factor of safety equal to three-fourths of the static factor of safety) for short duration loading.

Soil settlement is a function of footing dimensions and applied soil bearing pressure. In utilizing the above-mentioned allowable bearing capacity and provided our earthwork recommendations are implemented, foundation settlement due to structural loads is anticipated to be on the order of 1-inch or less. Differential static settlement may be taken as half of the static settlement (i.e., ½-inch over a horizontal span of 40 feet). Additionally, differential settlement should be anticipated between nearby columns or walls where a large differential loading condition exists. Settlement estimates should be updated by LGC Geotechnical when the final foundation plans are available.

Resistance to lateral loads can be provided by friction acting at the base of foundations and by passive earth pressure. For concrete/soil frictional resistance, an allowable coefficient of friction of 0.30 may be assumed with dead-load forces. An allowable passive lateral earth pressure of 250 psf per foot of depth (or pcf) to a maximum of 2,500 psf may be used for lateral resistance. Allowable passive pressure may be increased to 340 pcf (maximum of 3,400 psf) for short duration seismic loading. This passive pressure is applicable for level (ground slope equal to or flatter than 5 horizontal feet to 1-foot vertical) conditions only. Frictional resistance and passive pressure may be used in combination without reduction. We recommend that the upper foot of passive resistance be neglected if finished grade will not be covered with concrete or asphalt concrete. The provided allowable passive pressures are based on a factor of safety of 1.5 and 1.1 for static and seismic loading conditions, respectively.

4.4 Lateral Earth Pressures for Retaining Walls

The following preliminary lateral earth pressures may be used for any site retaining walls 10 feet or less. Lateral earth pressures are provided as equivalent fluid unit weights, in pound per square foot (psf) per foot of depth or pcf. These values do not contain an appreciable factor of safety, so

the retaining wall designer should apply the applicable factors of safety and/or load factors during design.

The following lateral earth pressures are presented on Table 4 below for approved select granular soils with a maximum of 35 percent fines (passing the No. 200 sieve per ASTM D-421/422) and Very Low expansion potential (EI of 20 or less per ASTM D4829). The wall designer should clearly indicate on the retaining wall plans the required sandy soil backfill criteria.

TABLE 4

Lateral Earth Pressures – Select Sandy Backfill

Conditions	Equivalent Fluid Unit Weight (pcf)
	Level Backfill
	Approved Soils
Active	35
At-Rest	55

If the wall can yield enough to mobilize the full shear strength of the soil, it can be designed for “active” pressure. If the wall cannot yield under the applied load, the earth pressure will be higher. This would include 90-degree corners of retaining walls. Such walls should be designed for “at-rest.” The equivalent fluid pressure values assume free-draining conditions. Retaining wall structures should be provided with appropriate drainage and appropriately waterproofed (Figure 3). Please note that waterproofing and outlet systems are not the purview of the geotechnical consultant. If conditions other than those assumed above are anticipated, the equivalent fluid pressure values should be provided on an individual-case basis by the geotechnical consultant.

Surcharge loading effects from any adjacent structures should be evaluated by the basement/retaining wall designer. The amount of surcharge loading on a proposed retaining wall structure is primarily a function of the distance, magnitude and lateral extents of the surcharge loading and should be evaluated on a case-by-case basis. In addition to the recommended lateral earth pressure, basement/retaining walls adjacent to streets should be designed to resist vehicular traffic if applicable. Uniform surcharges may be estimated using the applicable coefficient of lateral earth pressure using a rectangular distribution. A factor of 0.5 and 0.3 may be used for at-rest and active conditions, respectively for a level backfill. The vertical traffic surcharge may be determined by the structural designer. The structural designer should contact the geotechnical consultant for any required geotechnical input in estimating any applicable surcharge loads.

If required, the retaining wall designer may use a seismic lateral earth pressure increment of 5 pcf for a level backfill condition. This increment should be applied in addition to the provided static lateral earth pressure using a triangular distribution with the resultant acting at H/3 in relation to the base of the retaining structure (where H is the retained height). For the

restrained, at-rest condition, the seismic increment may be added to the applicable active lateral earth pressure (in lieu of the at-rest lateral earth pressure) when analyzing short duration seismic loading. Per Section 1803.5.12 of the 2019 CBC, the seismic lateral earth pressure is applicable to structures assigned to Seismic Design Category D through F for retaining wall structures supporting more than 6 feet of backfill height. The provided seismic lateral earth pressure should not be used for retaining walls exceeding 10 feet in height. If a retaining wall greater than 10 feet in height is proposed or a retaining wall with a sloping backfill condition, the retaining wall designer should contact the geotechnical consultant for specific seismic lateral earth pressure increments based on the configuration of the planned retaining wall structures. Seismic lateral earth pressures are estimated using the procedure outlined by the Structural Engineers Association of California (Lew, et al, 2010).

Soil bearing and lateral resistance (friction coefficient and passive resistance) are provided in Section 4.3. Earthwork considerations (temporary backcuts, backfill, compaction, etc.) for retaining walls are provided in Section 4.1 (Site Earthwork) and the subsequent earthwork related sub-sections.

4.5 Preliminary Pavement Sections

The following preliminary minimum asphalt concrete (AC) pavement sections are provided in Table 5 based on an R-value of 20 and for requested on-site Traffic Indices (TI) up to 10.0. These recommendations should be confirmed with R-value testing of representative near-surface soils at the completion of earthwork. Determination of the Traffic Index is not the purview of the geotechnical consultant. Final asphalt concrete pavement sections should be confirmed by the project civil engineer based upon the projected design Traffic Index. If requested, LGC Geotechnical will provide sections for alternate TI values.

TABLE 5

Preliminary Asphalt Concrete Paving Section Options

Traffic Index	8.0	9.0	10.0
R -Value Subgrade	20	20	20
AC Thickness	5.0 inches	5.5 inches	6.5 inches
Aggregate Base Thickness	13.5 inches	16.0 inches	17.5 inches

The following provided preliminary Portland Cement Concrete (PCC) pavement section is based on the guidelines of the American Concrete Institute (ACI 330R-08 & ACI 330.2R-17). For the final design section, we recommend a traffic study be performed as LGC Geotechnical does not perform traffic engineering. Traffic study should include the design vehicle (number of axles and load per axle) and estimated number of daily repetitions/trips. Based on an assumed Traffic Category C with an Average Daily Truck Traffic (ADTT) of 575 (Approximate TI of 10), we recommend a preliminary section of a minimum of 6.5 inches of concrete over 4 inches of compacted aggregate base over compacted subgrade. The concrete should have a minimum compressive strength of 4,000 psi and a minimum flexural strength of 550 psi at the time the pavement is subjected to traffic. Steel reinforcement is not required (ACI, 2013 & 2017). This

pavement section assumes that edge restraints like a curb and gutter will be provided. To reduce the potential (but not eliminate) for cracking, paving should provide control joints at regular intervals not exceeding 12 feet in each direction. Decreasing the spacing of these joints will further reduce, but not eliminate the potential for unsightly cracking. Preliminary pavement section is based on a 20-year design. Truck loading is defined one 16-kip axle and two 32-kip tandem axles (80 kips). Alternate section(s) may be provided based on anticipated specific traffic loadings and repetitions provided by others. LGC Geotechnical does not perform traffic engineering and determination of traffic loading is not the purview of the geotechnical consultant.

The thicknesses shown are for minimum thicknesses. Increasing the thickness of any or all of the above layers will reduce the likelihood of the pavement experiencing distress during its service life. The above recommendations are based on the assumption that proper maintenance and irrigation of the areas adjacent to the roadway will occur through the design life of the pavement. Failure to maintain a proper maintenance and/or irrigation program may jeopardize the integrity of the pavement.

Earthwork recommendations regarding aggregate base and subgrade are provided in the previous section "Site Earthwork" and the related sub-sections of this report.

4.6 Soil Corrosivity

Although not corrosion engineers (LGC Geotechnical is not a corrosion consultant), several governing agencies in Southern California require the geotechnical consultant to determine the corrosion potential of soils to buried concrete and metal facilities. We therefore present the results of our testing with regard to corrosion for the use of the client and other consultants, as they determine necessary.

Corrosion testing indicated soluble sulfate contents less than approximately 0.02 percent, a chloride content of 21 ppm, pH of 8.6, and a minimum resistivity of 2,590 ohm-centimeters. Based on Caltrans Corrosion Guidelines (2021), soils are considered corrosive if the pH is 5.5 or less, or the chloride concentration is 500 ppm or greater, or the sulfate concentration is 1,500 ppm (0.15 percent) or greater.

Based on laboratory sulfate test results, the near surface soils are designated to a class "S0" per ACI 318, Table 19.3.1.1 with respect to sulfates.

4.7 Nonstructural Concrete Flatwork

Nonstructural concrete (such as flatwork, sidewalks, etc.) has a potential for cracking due to changes in soil volume related to soil-moisture fluctuations. To reduce the potential for excessive cracking and lifting, concrete should be designed in accordance with the minimum guidelines outlined in Table 6 on the following page. These guidelines will reduce the potential for irregular cracking and promote cracking along construction joints but will not eliminate all cracking or lifting. Thickening the concrete and/or adding additional reinforcement will further reduce cosmetic distress.

TABLE 6

Nonstructural Concrete Flatwork for Very Low/Low Expansion Potential

	Flatwork	City Sidewalk Curb and Gutters
Minimum Thickness (in.)	4 (full)	City/Agency Standard
Presoaking	Wet down prior to placing	City/Agency Standard
Reinforcement	No. 3 at 24 inches on centers	City/Agency Standard
Crack Control Joints	Saw cut or deep open tool joint to a minimum of 1/3 the concrete thickness	City/Agency Standard
Maximum Joint Spacing	6 feet or quarter cut whichever is closer	City/Agency Standard
Aggregate Base Thickness (in.)	—	City/Agency Standard

To reduce the potential for nonstructural concrete flatwork to separate from entryways and doorways, the owner may elect to install dowels to tie these two elements together.

4.8 Surface Drainage and Landscaping

Landscape design should limit the potential for surface water to penetrate the soils adjacent to the proposed structures and improvements.

4.8.1 General

Surface drainage should be carefully taken into consideration during precise grading, building construction, future landscaping, and throughout the design life of the industrial structure. Positive drainage should be provided to direct surface water away from improvements and towards either the street or other suitable drainage devices. Ponding of water, adjacent to any structural improvement foundation, must be avoided. The performance of structural foundations is dependent upon maintaining adequate surface drainage away from them, thereby reducing excessive moisture fluctuations. From a geotechnical perspective, area drains, drainage swales, and finished grade soils should be aligned so as to transport surface water to a minimum distance of 5 feet away from the proposed foundations. Roof gutters and downspout systems should be discharged directly to a pipe or to a paved surface with a positive gradient away from the building and should not outlet directly into unpaved landscape areas.

Decorative gravel tends to act as a reservoir trapping surface water; therefore, we do

not recommend it be used adjacent to buildings unless the system is designed with a subsurface drainage system and is properly lined.

4.8.2 Precise Grading

From a geotechnical perspective, we recommend that compacted finished grade soils adjacent to the proposed industrial structures be sloped away from the proposed structures and towards an approved drainage device or unobstructed swale. Drainage swales, wherever feasible, should not be constructed within 5 feet of buildings. Where lot and building geometry necessitates that the drainage swales be routed closer than 5 feet to structural foundations, we recommend the use of area drains together with drainage swales. Drainage swales used in conjunction with area drains should be designed by the project civil engineer so that a properly constructed and maintained system will prevent ponding within 5 feet of the foundation. Code compliance of grades is not the purview of the geotechnical consultant. We do not recommend that area drains be connected to basement/retaining subdrains.

Planters with open bottoms adjacent to buildings should be avoided. Planters should not be designed adjacent to buildings unless provisions for drainage, such as catch basins, liners, and/or area drains, are made. Overwatering must be avoided.

4.8.3 Landscaping

Planters adjacent to a building or structure should be avoided wherever possible or be properly designed (e.g., lined with a membrane and properly outlet), to reduce the penetration of water into the adjacent footing subgrades and thereby reduce moisture related damage to the foundation. Planting areas at grade should be provided with appropriate positive drainage. Wherever possible, exposed soil areas should be above adjacent paved grades to facilitate drainage. Planters should not be depressed below adjacent paved grades unless provisions for drainage, such as multiple depressed area drains, are constructed. Adequate drainage gradients, devices, and curbing should be provided to prevent runoff from adjacent pavement or walks into the planting areas. Irrigation methods should promote uniformity of moisture in planters and beneath adjacent concrete flatwork. Overwatering and underwatering of landscape areas must be avoided. Irrigation levels should be kept to the absolute minimum level necessary to maintain healthy plant life.

Area drain inlets should be maintained and kept clear of debris in order to properly function. The building owner should also be made aware that excessive irrigation of neighboring properties can cause seepage and moisture conditions on adjacent lots.

The impact of heavy irrigation or inadequate runoff gradients can create perched water conditions. This may result in seepage or shallow groundwater conditions where previously none existed. Maintaining adequate surface drainage and controlled irrigation will significantly reduce the potential for nuisance-type moisture problems. To reduce differential earth movements such as heaving and shrinkage due to the change in moisture content of foundation soils, which may cause distress to a structure

and associated improvements, moisture content of the soils surrounding the structure should be kept as relatively constant as possible.

4.9 Subsurface Water Infiltration

Recent regulatory changes have occurred that mandate that storm water be infiltrated below grade rather than collected in a conventional storm drain system. It should be noted that collecting and concentrating surface water for the purpose of intentionally infiltrating it below grade, conflicts with the geotechnical engineering objective of directing surface water away from slopes, structures and other improvements. The geotechnical stability and integrity of a site is reliant upon appropriately handling surface water. In general, we do not recommend that surface water be intentionally infiltrated into the subsurface soils.

If it is determined that water must be infiltrated due to regulatory requirements, we recommend the absolute minimum amount of water be infiltrated and that the infiltration areas not be located near slopes or near settlement sensitive existing/proposed improvements. Contamination and environmental suitability of the site for infiltration is not the purview of the geotechnical consultant and should be evaluated by others. LGC Geotechnical only addressed the geotechnical issues associated with stormwater infiltration.

As with all systems that are designed to concentrate surface flow and direct the water into the subsurface soils, some minor settlement, nuisance type localized saturation and/or other water related issues should be expected. Due to variability in geologic and hydraulic conductivity characteristics, these effects may be experienced at the onsite location and/or potentially at other locations well beyond the physical limits of the subject site. Infiltrated water may enter underground utility pipe zones or flow along heterogeneous soil layers or geologic structure and migrate laterally impacting other improvements which may be located far away or at an elevation much different than the infiltration source.

Based on the results of our field infiltration testing the observed (no factor of safety) infiltration rates were 4.5 and 6.9 inches per hour (refer to Table 1). The design infiltration rate shall be determined by dividing the observed infiltration rate by a series of safety factors for site suitability and design considerations that are the purview of both the geotechnical consultant and designer of the infiltration system (County of San Bernardino, 2013). The recommended geotechnical factors of safety that are to be used to determine the design infiltration rate are provided in Table 7.

TABLE 7

Geotechnical Factors of Safety for Design Infiltration Rate

A: Site Suitability Considerations (From Table VII.3)	
Consideration	Factor of Safety (F.S.)
Soil Assessment Methods	2
Texture Class	1
Site Soil Variability	2
Depth to Groundwater/Impervious Layer	1
Calculated Suitability Assessment Factor of Safety	1.5
B: Design Related Considerations (From Table VII.4)	
Consideration	Factor of Safety (F.S.)
Tributary Size Area	Per Infiltration Designer
Level of Pretreatment	Per Infiltration Designer
Redundancy of Treatment	Per Infiltration Designer
Compaction during Construction	2
Calculated Design Factor of Safety	Per Infiltration Designer
Combined F.S.= Suitability F.S x Design F.S.	TBD

Per the requirements of the San Bernardino County testing guidelines (2013), subsurface materials should have a design infiltration rate equal to or greater than 0.3 inches per hour. The factor of safety used to determine the design infiltration rate is determined by multiplying the calculated suitability assessment factor of safety of 1.5 by the design factor of safety which is to be determined by the infiltration system designer. The design infiltration rate is thereby equal to the Measured Infiltration Rate provided in Table 1 (inches per hour) divided by the product of 1.5 times the calculated design factor of safety. The combined factor of safety must be a minimum of 2.0 but need not exceed 9.0. Results of field infiltration testing are provided in Appendix D.

Please note that the infiltration values reported herein are for native materials only and are not for compacted fill. Water discharge from any infiltration systems should not occur within the zone of influence of foundation footings (column and load bearing wall locations). For preliminary purposes we recommend a minimum setback of 15 feet from the structural improvements. Infiltration shall not be permitted directly on or into compacted fill soils. The infiltration values provided are based on clean water and this requires the removal of trash, debris, soil particles, etc., and on-going maintenance. Over time, siltation, plugging and clogging of the system may reduce the infiltration rate and subsequently reduce the effectiveness of the infiltration system. Any designed infiltration system will require routine periodic maintenance. It should be noted that methods to prevent this shall be the sole responsibility of the infiltration designer and are not the purview of the geotechnical consultant. If adequate measures cannot be incorporated into the design and maintenance of the system, then the infiltration rates may need to be further reduced. These and other factors should be considered in selecting a design infiltration rate.

We recommend the design of any infiltration system include at least one redundancy or overflow system. It may be prudent to provide an overflow system connected directly to a storm drain system in order to prevent failure of the infiltration system, either as a result of lower than anticipated infiltration with time and/or very high flow volumes.

LGC Geotechnical should be provided with details for any planned required infiltration system early in the design process for geotechnical input.

4.10 Pre-Construction Documentation and Construction Monitoring

A program of documentation and monitoring should be devised and put into practice before the onset of any groundwork. LGC Geotechnical can perform these services at your request. This should include, but not necessarily be limited to, detailed documentation of the existing improvements, buildings, and utilities around the area of proposed excavation, with particular attention to any distress that is already present prior to the start of work. At the completion of construction, we recommend that the adjacent properties be re-documented to confirm their condition after potentially damaging activities are completed. In the event of future claims, any post-construction damage may be attributed to other causes.

4.11 Geotechnical Plan Review

Project plans (e.g., grading, foundation, retaining wall, etc.) and any other improvement plans, and final project drawings should be reviewed by this office prior to construction to verify that our geotechnical recommendations, provided herein, have been appropriately incorporated. Additional or modified geotechnical recommendations may be required based on the proposed design.

4.12 Geotechnical Observation and Testing During Construction

The recommendations provided in this report are based on limited subsurface observations and geotechnical analysis. The interpolated subsurface conditions should be checked in the field during construction by a representative of LGC Geotechnical. Geotechnical observation and testing is required per Section 1705 of the 2019 California Building Code (CBC).

Geotechnical observation and/or testing should be performed by LGC Geotechnical at the following stages:

- During grading (removal bottoms, fill placement, etc.);
- During retaining wall backfill and compaction;
- During utility trench backfill and compaction;
- During drilling and backfilling of holes in bottom of infiltration system;
- During precise grading;
- Preparation of building pads and other concrete-flatwork subgrades, and prior to placement of aggregate base or concrete;

- After building and wall footing excavation and prior to placement of steel reinforcement and/or concrete;
- Preparation of pavement subgrade and placement of aggregate base; and
- When any unusual soil conditions are encountered during any construction operation subsequent to issuance of this report.

5.0 LIMITATIONS

Our services were performed using the degree of care and skill ordinarily exercised, under similar circumstances, by reputable engineers and geologists practicing in this or similar localities. No other warranty, expressed or implied, is made as to the conclusions and professional advice included in this report. The samples taken and submitted for laboratory testing, the observations made, and the in-situ field testing performed are believed representative of the entire project; however, soil and geologic conditions revealed by excavation may be different than our preliminary findings. If this occurs, the changed conditions must be evaluated by the project soils engineer and geologist and design(s) adjusted as required or alternate design(s) recommended.

This report is issued with the understanding that it is the responsibility of the owner, or of his/her representative, to ensure that the information and recommendations contained herein are brought to the attention of the architect and/or project engineer and incorporated into the plans, and the necessary steps are taken to see that the contractor and/or subcontractor properly implements the recommendations in the field. The contractor and/or subcontractor should notify the owner if they consider any of the recommendations presented herein to be unsafe.

The findings of this report are valid as of the present date. However, changes in the conditions of a property can and do occur with the passage of time, whether they be due to natural processes or the works of man on this or adjacent properties. Therefore, the findings, conclusions, and recommendations presented in this report can be relied upon only if LGC Geotechnical has the opportunity to observe the subsurface conditions during grading and construction of the project, in order to confirm that our preliminary findings are representative for the site.

In addition, changes in applicable or appropriate standards may occur, whether they result from legislation or the broadening of knowledge. Accordingly, the findings of this report may be invalidated wholly or partially by changes outside our control. Therefore, this report is subject to review and modification, and should not be relied upon after a period of 3 years.



FIGURE 1
Site Location Map

PROJECT NAME	IPG - Mojave 68, Victorville
PROJECT NO.	22124-01
ENG. / GEOL.	BTZ/KBC
SCALE	Not to Scale
DATE	October 2022

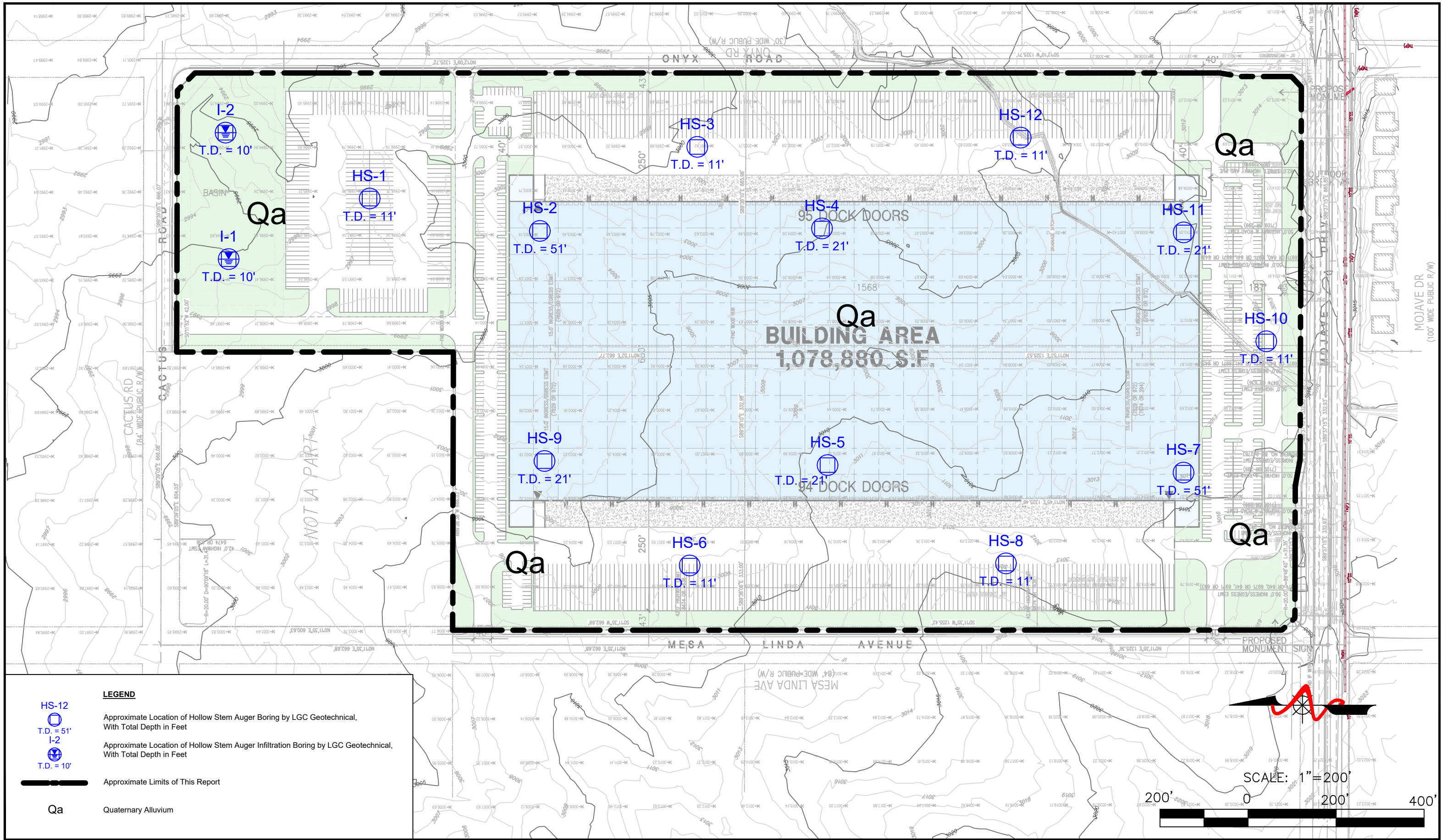

LEGEND

<p>HS-12 T.D. = 51'</p> <p>I-2 T.D. = 10'</p> <p>— — — — — Approximate Limits of This Report</p> <p>Qa Quaternary Alluvium</p>	<p>Approximate Location of Hollow Stem Auger Boring by LGC Geotechnical, With Total Depth in Feet</p> <p>Approximate Location of Hollow Stem Auger Infiltration Boring by LGC Geotechnical, With Total Depth in Feet</p>
--	--



LGC Geotechnical, Inc.
 131 Calle Iglesia, Ste. 200
 San Clemente, CA 92672
 TEL (949) 369-6141 FAX (949) 369-6142

Figure 2
Geotechnical Site Map

PROJECT NAME	IPG - Mojave 68, Victorville
PROJECT NO.	22124-01
ENG. / GEOL.	BTZ/KBC
SCALE	1" = 200'
DATE	October 2022

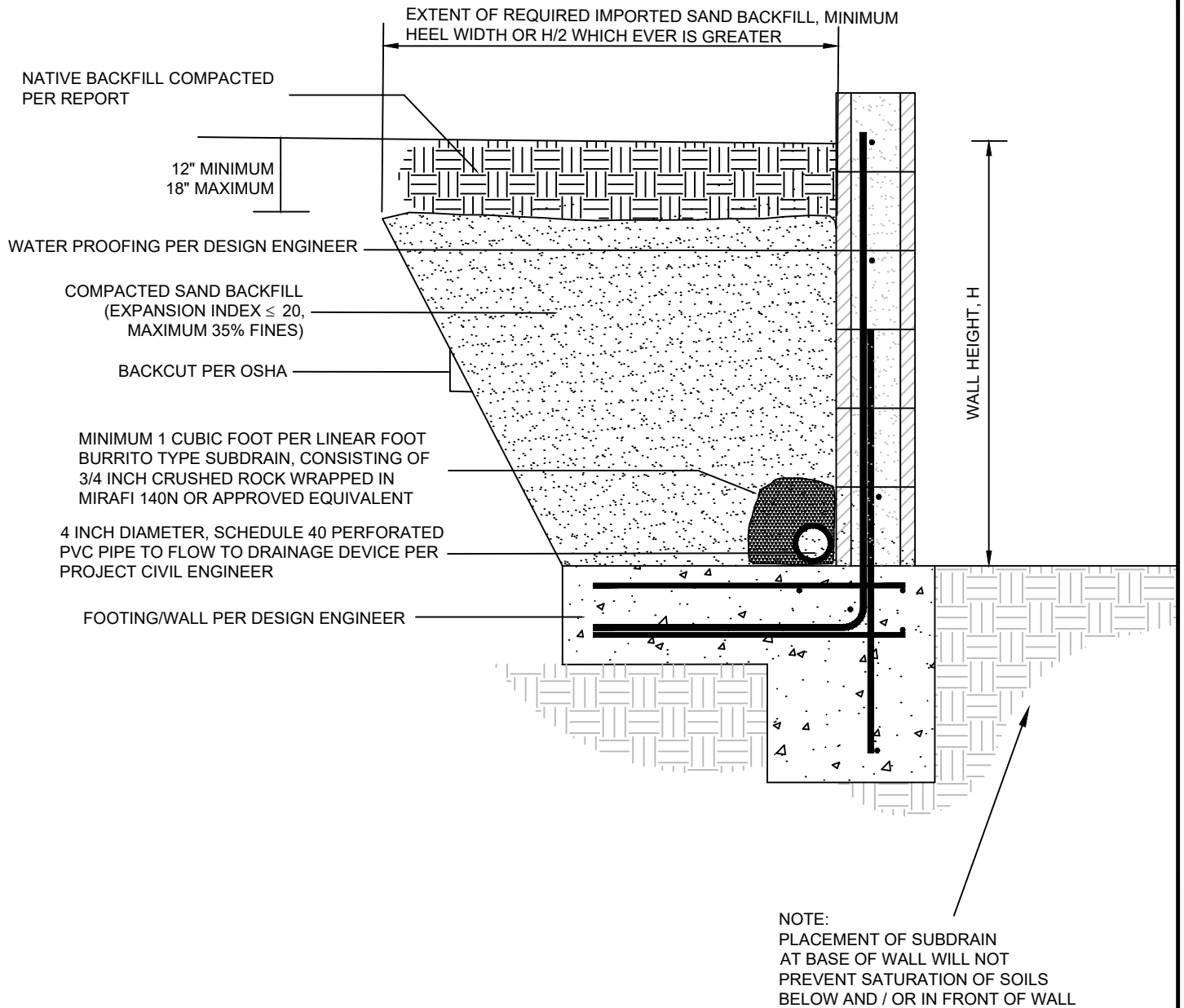

FIGURE 3
Retaining Wall
Backfill Detail

PROJECT NAME	IPG - Mojave 68, Victorville
PROJECT NO.	22124-01
ENG. / GEOL.	BTZ/KBC
SCALE	Not to Scale
DATE	October 2022

Appendix A
References

APPENDIX A

References

- American Concrete Institute, 2013, Guide for the Design and Construction of Concrete Parking Lots (ACI 330R-08), fifteenth printing, November 2013.
- _____, 2014, Building Code Requirements for Structural Concrete (ACI 318-14) and Commentary (ACI 318R-14).
- _____, 2017, Guide for the Design and Construction of Concrete Site Paving for Industrial and Trucking Facilities (ACI 3302R-17), May 2017.
- American Society of Civil Engineers (ASCE), 2017, Minimum Design Loads for Buildings and Other Structures, ASCE/SEI 7-16, 2017.
- _____, 2018, Standard 7-16, Minimum Design Loads for Buildings and Associated Criteria for Buildings and Other Structures, Supplement 1, effective: December 12, 2018.
- American Society for Testing and Materials (ASTM), Volume 04.08 Soil and Rock (I):D420 – D5876.
- California Building Standards Commission, 2019, California Building Code (CBC), California Code of Regulations Title 24, Volumes 1 and 2, dated July 2019.
- California Department of Transportation (Caltrans), 2021, Corrosion Guidelines, Version 3.2, dated May 2021.
- California Department of Water Resources (CDWR), 2022, Water Data Library, retrieved August 25, 2022, from <https://wdl.water.ca.gov/waterdatalibrary/>
- California Geological Survey (CGS), (Previously California Division of Mines and Geology [CDMG]), 2002, California Geomorphic Provinces, CGS Note 36, dated 2002.
- _____, 2008, California Geological Survey Special Publication 117A: Guidelines for Evaluating and Mitigating Seismic Hazards in California.
- _____, 2018, Earthquake Fault Zones, Special Publication 42, Revised 2018.
- _____, 2022, Earthquake Zones of Required Investigation, web application, retrieved August 25, 2022, from <https://maps.conservation.ca.gov/cgs/EQZApp/>
- City of Victorville, 2007, Street Design Standards, Standard S-25, revised June 1, 2007.
- County of San Bernardino, 2013, Technical Guidance Document for Water Quality Management Plans, dated September 19, 2013.

Dibblee, Thomas W., Jr., 2008, Geologic Map of the Shadow Mountains and Victorville, 15 Minute Quadrangles, San Bernardino and Los Angeles Counties, California, Dibblee Geology Center Map #DF-387, scale: 1:62,500, dated 2008.

HPA Architecture, 2022, Conceptual Site Plan, Mojave Drive & Onyx Road, City of Victorville, Scheme 5, scale 1"=100', plan dated July 15, 2022.

Kier + Wright, 2022, Topographic Survey of Mojave Dr. for Industrial Property Group, Inc., job number A22221, scale 1"=80', plan dated July 2022.

Lew, et al, 2010, Seismic Earth Pressures on Deep Basements, Structural Engineers Association of California (SEAOC) Convention Proceedings.

Structural Engineers Association of California (SEAOC), 2022, Seismic Design Maps, Retrieved August 25, 2022, from <https://seismicmaps.org/>

United States Geological Survey (USGS), 2014, Unified Hazard Tool, Dynamic: Conterminous U.S. 2014 (update) (v4.2.0), Retrieved August 25, 2022, 2022, from: <https://earthquake.usgs.gov/hazards/interactive/>

Appendix B
Boring Logs

Geotechnical Boring Log Borehole HS-1

Date: 9/12/2022	Drilling Company: Choice Drilling
Project Name: Mojave 68 - Victorville	Type of Rig: Truck Mounted
Project Number: 22124-01	Drop: 30" Hole Diameter: 6"
Elevation of Top of Hole: ~2997' MSL	Drive Weight: 140 pounds
Hole Location: See Geotechnical Map	Page 1 of 1

Elevation (ft)	Depth (ft)	Graphic Log	Sample Number	Blow Count	Dry Density (pcf)	Moisture (%)	USCS Symbol	DESCRIPTION	Type of Test
2995	0	B-1	R-1	19 32 40	119.8	4.9	ML	@ 0' - Sandy SILT: light brown, dry	
	5		SPT-1	5 6 6		1.8	SM	@ 2.5' - Sandy SILT: light brown, slightly moist, hard, with caliche @ 5' - Silty SAND: light yellowish gray, dry, medium dense	
2990			R-2	18 30 39	107.3	3.6	ML	@ 7.5' - Sandy SILT: light brown, slightly moist, hard	
	10		SPT-2	6 8 10		4.6	SM	@ 10' - Silty SAND: light brown, slightly moist, medium dense	SA
2985								Total Depth = 11' Groundwater Not Encountered Backfilled with Cuttings on 9/12/2022	
	15								
	-20								
	20								
	-25								
	25								
	30								



THIS SUMMARY APPLIES ONLY AT THE LOCATION OF THIS BORING AND AT THE TIME OF DRILLING. SUBSURFACE CONDITIONS MAY DIFFER AT OTHER LOCATIONS AND MAY CHANGE AT THIS LOCATION WITH THE PASSAGE OF TIME. THE DATA PRESENTED IS A SIMPLIFICATION OF THE ACTUAL CONDITIONS ENCOUNTERED. THE DESCRIPTIONS PROVIDED ARE QUALITATIVE FIELD DESCRIPTIONS AND ARE NOT BASED ON QUANTITATIVE ENGINEERING ANALYSIS.



SAMPLE TYPES:	TEST TYPES:
B BULK SAMPLE	DS DIRECT SHEAR
R RING SAMPLE (CA Modified Sampler)	MD MAXIMUM DENSITY
G GRAB SAMPLE	SA SIEVE ANALYSIS
SPT STANDARD PENETRATION TEST SAMPLE	S&H SIEVE AND HYDROMETER
	EI EXPANSION INDEX
	EN CONSOLIDATION
	CR CORROSION
	AL ATTERBERG LIMITS
	CO COLLAPSE/SWELL
	RV R-VALUE
	#200 % PASSING # 200 SIEVE



Geotechnical Boring Log Borehole HS-2

Date: 9/12/2022	Drilling Company: Choice Drilling
Project Name: Mojave 68 - Victorville	Type of Rig: Truck Mounted
Project Number: 22124-01	Drop: 30" Hole Diameter: 6"
Elevation of Top of Hole: ~3003' MSL	Drive Weight: 140 pounds
Hole Location: See Geotechnical Map	Page 1 of 2

Elevation (ft)	Depth (ft)	Graphic Log	Sample Number	Blow Count	Dry Density (pcf)	Moisture (%)	USCS Symbol	DESCRIPTION	Type of Test
	0						SC	@ 0' - Clayey SAND: light brown, slightly moist	FI CR
3000			SPT-1	7 13 18		4.4		@ 2.5' - Silty SAND: light brown, slightly moist, dense	
	5	B-1	R-1	17 22 35	121.0	2.5	SP-SM	@ 5' - SAND with Silt: light reddish brown, dry, dense	
2995			SPT-2	11 13 16		4.9	SM	@ 7.5' - Silty SAND: light brown, slightly moist, dense	SA
	10		R-2	20 32 50	112.3	2.1		@ 10' - Silty SAND: light olive brown, dry, very dense	CN
2990			SPT-3	7 10 12		4.1	SC	@ 15' - Clayey SAND: yellowish brown, slightly moist, medium dense	SA
2985			R-3	25 45 50/5"	119.9	4.4	ML	@ 20' - Sandy SILT: light brown, slightly moist, hard	
2980			SPT-4	9 10 13		4.0	CL-ML	@ 25' - Sandy SILT to CLAY: grayish brown, slightly moist, very stiff	AL #200
2975									
	30								

	<p style="font-size: small;">THIS SUMMARY APPLIES ONLY AT THE LOCATION OF THIS BORING AND AT THE TIME OF DRILLING. SUBSURFACE CONDITIONS MAY DIFFER AT OTHER LOCATIONS AND MAY CHANGE AT THIS LOCATION WITH THE PASSAGE OF TIME. THE DATA PRESENTED IS A SIMPLIFICATION OF THE ACTUAL CONDITIONS ENCOUNTERED. THE DESCRIPTIONS PROVIDED ARE QUALITATIVE FIELD DESCRIPTIONS AND ARE NOT BASED ON QUANTITATIVE ENGINEERING ANALYSIS.</p>	<table style="width: 100%; font-size: x-small;"> <tr> <td>SAMPLE TYPES:</td> <td>TEST TYPES:</td> </tr> <tr> <td>B BULK SAMPLE</td> <td>DS DIRECT SHEAR</td> </tr> <tr> <td>R RING SAMPLE (CA Modified Sampler)</td> <td>MD MAXIMUM DENSITY</td> </tr> <tr> <td>G GRAB SAMPLE</td> <td>SA SIEVE ANALYSIS</td> </tr> <tr> <td>SPT STANDARD PENETRATION TEST SAMPLE</td> <td>S&H SIEVE AND HYDROMETER</td> </tr> <tr> <td></td> <td>EI EXPANSION INDEX</td> </tr> <tr> <td></td> <td>CN CONSOLIDATION</td> </tr> <tr> <td></td> <td>CR CORROSION</td> </tr> <tr> <td></td> <td>AL ATTERBERG LIMITS</td> </tr> <tr> <td></td> <td>CO COLLAPSE/SWELL</td> </tr> <tr> <td></td> <td>RV R-VALUE</td> </tr> <tr> <td></td> <td>#200 % PASSING # 200 SIEVE</td> </tr> </table> <p style="font-size: x-small; margin-top: 10px;">  GROUNDWATER TABLE </p>	SAMPLE TYPES:	TEST TYPES:	B BULK SAMPLE	DS DIRECT SHEAR	R RING SAMPLE (CA Modified Sampler)	MD MAXIMUM DENSITY	G GRAB SAMPLE	SA SIEVE ANALYSIS	SPT STANDARD PENETRATION TEST SAMPLE	S&H SIEVE AND HYDROMETER		EI EXPANSION INDEX		CN CONSOLIDATION		CR CORROSION		AL ATTERBERG LIMITS		CO COLLAPSE/SWELL		RV R-VALUE		#200 % PASSING # 200 SIEVE
SAMPLE TYPES:	TEST TYPES:																									
B BULK SAMPLE	DS DIRECT SHEAR																									
R RING SAMPLE (CA Modified Sampler)	MD MAXIMUM DENSITY																									
G GRAB SAMPLE	SA SIEVE ANALYSIS																									
SPT STANDARD PENETRATION TEST SAMPLE	S&H SIEVE AND HYDROMETER																									
	EI EXPANSION INDEX																									
	CN CONSOLIDATION																									
	CR CORROSION																									
	AL ATTERBERG LIMITS																									
	CO COLLAPSE/SWELL																									
	RV R-VALUE																									
	#200 % PASSING # 200 SIEVE																									

Geotechnical Boring Log Borehole HS-2

Date: 9/12/2022	Drilling Company: Choice Drilling
Project Name: Mojave 68 - Victorville	Type of Rig: Truck Mounted
Project Number: 22124-01	Drop: 30" Hole Diameter: 6"
Elevation of Top of Hole: ~3003' MSL	Drive Weight: 140 pounds
Hole Location: See Geotechnical Map	Page 2 of 2

Elevation (ft)	Depth (ft)	Graphic Log	Sample Number	Blow Count	Dry Density (pcf)	Moisture (%)	USCS Symbol	DESCRIPTION	Type of Test
2970	30		R-4	25 40 50/4"	118.8	5.8	ML	@ 30' - Sandy SILT: dark olive gray, slightly moist, hard	
2965	35		SPT-5	16 22 28		4.4	SM	@ 35' - Silty SAND: olive gray, slightly moist, very dense	
2960	40		R-5	42 50/4"	107.7	8.2	ML	@ 40' - SILT: light grayish brown, slightly moist, hard	
2955	45		SPT-6	14 19 28		16.7	CL	@ 45' - CLAY: light grayish brown, moist, hard, with caliche	
2950	50		R-6	45 50/3"	116.6	8.6	ML	@ 50' - Sandy SILT: yellowish brown, slightly moist, hard	
2945	55							Total Depth = 51' Groundwater Not Encountered Caving: Hole Measured Approximately 50' After Removal of Augers Backfilled with Cuttings on 9/12/2022	
	60								



THIS SUMMARY APPLIES ONLY AT THE LOCATION OF THIS BORING AND AT THE TIME OF DRILLING. SUBSURFACE CONDITIONS MAY DIFFER AT OTHER LOCATIONS AND MAY CHANGE AT THIS LOCATION WITH THE PASSAGE OF TIME. THE DATA PRESENTED IS A SIMPLIFICATION OF THE ACTUAL CONDITIONS ENCOUNTERED. THE DESCRIPTIONS PROVIDED ARE QUALITATIVE FIELD DESCRIPTIONS AND ARE NOT BASED ON QUANTITATIVE ENGINEERING ANALYSIS.

SAMPLE TYPES:
 B BULK SAMPLE
 R RING SAMPLE (CA Modified Sampler)
 G GRAB SAMPLE
 SPT STANDARD PENETRATION TEST SAMPLE

GROUNDWATER TABLE

TEST TYPES:
 DS DIRECT SHEAR
 MD MAXIMUM DENSITY
 SA SIEVE ANALYSIS
 S&H SIEVE AND HYDROMETER
 EI EXPANSION INDEX
 CN CONSOLIDATION
 CR CORROSION
 AL ATTERBERG LIMITS
 CO COLLAPSE/SWELL
 RV R-VALUE
 #200 % PASSING # 200 SIEVE

Geotechnical Boring Log Borehole HS-3

Date: 9/12/2022	Drilling Company: Choice Drilling
Project Name: Mojave 68 - Victorville	Type of Rig: Truck Mounted
Project Number: 22124-01	Drop: 30" Hole Diameter: 6"
Elevation of Top of Hole: ~3001' MSL	Drive Weight: 140 pounds
Hole Location: See Geotechnical Map	Page 1 of 1

Elevation (ft)	Depth (ft)	Graphic Log	Sample Number	Blow Count	Dry Density (pcf)	Moisture (%)	USCS Symbol	DESCRIPTION	Type of Test
3000	0	B-1					ML	@ 0' - Sandy SILT: dark yellowish brown, dry	RV
			R-1	25 40 50/5"	120.5	3.8	SM	@ 2.5' - Silty SAND: light brown, slightly moist, very dense	
2995	5		SPT-1	8 11 14		2.9	ML	@ 5' - Sandy SILT: light grayish brown, slightly moist, hard	
			R-2	16 24 32	110.1	6.0	SM	@ 7.5' - Silty SAND: light brown, slightly moist, dense	
2990	10		SPT-1	6 7 9		3.0		@ 10' - Silty SAND: light brownish gray, slightly moist, medium dense	
								Total Depth = 11' Groundwater Not Encountered Backfilled with Cuttings on 9/12/2022	
2985	15								
2980	20								
2975	25								
	30								



THIS SUMMARY APPLIES ONLY AT THE LOCATION OF THIS BORING AND AT THE TIME OF DRILLING. SUBSURFACE CONDITIONS MAY DIFFER AT OTHER LOCATIONS AND MAY CHANGE AT THIS LOCATION WITH THE PASSAGE OF TIME. THE DATA PRESENTED IS A SIMPLIFICATION OF THE ACTUAL CONDITIONS ENCOUNTERED. THE DESCRIPTIONS PROVIDED ARE QUALITATIVE FIELD DESCRIPTIONS AND ARE NOT BASED ON QUANTITATIVE ENGINEERING ANALYSIS.

SAMPLE TYPES:	TEST TYPES:
B BULK SAMPLE	DS DIRECT SHEAR
R RING SAMPLE (CA Modified Sampler)	MD MAXIMUM DENSITY
G GRAB SAMPLE	SA SIEVE ANALYSIS
SPT STANDARD PENETRATION TEST SAMPLE	S&H SIEVE AND HYDROMETER
	EI EXPANSION INDEX
	CN CONSOLIDATION
	CR CORROSION
	AL ATTERBERG LIMITS
	CO COLLAPSE/SWELL
	RV R-VALUE
	#200 % PASSING # 200 SIEVE



Geotechnical Boring Log Borehole HS-4

Date: 9/12/2022	Drilling Company: Choice Drilling
Project Name: Mojave 68 - Victorville	Type of Rig: Truck Mounted
Project Number: 22124-01	Drop: 30" Hole Diameter: 6"
Elevation of Top of Hole: ~3005' MSL	Drive Weight: 140 pounds
Hole Location: See Geotechnical Map	Page 1 of 1

Elevation (ft)	Depth (ft)	Graphic Log	Sample Number	Blow Count	Dry Density (pcf)	Moisture (%)	USCS Symbol	DESCRIPTION	Type of Test
	0						SM	@ 0' - Silty SAND: light reddish brown, dry	MD
			SPT-1	7 11 14		3.7		@ 2.5' - Silty SAND: light reddish brown, slightly moist, dense	
3000	5	B-1	R-1	17 24 29	121.3	1.9		@ 5' - Silty SAND: light olive gray, dry, dense	CN
			SPT-2	15 24 19		4.6	ML	@ 7.5' - Sandy SILT: light grayish brown, slight moist, hard	
2995	10		R-2	38 50/2"	105.7	5.1	SM	@ 10' - Silty SAND: light olive brown, slightly moist, very dense	
			SPT-3	5 6 10		2.4	ML	@ 15' - Sandy SILT: gray, slightly moist, very stiff	
2990	15								
2985	20		R-3	40 50/5"	104.3	3.1	SM	@ 20' - Silty SAND: gray, slightly moist, very dense	
								Total Depth = 21' Groundwater Not Encountered Caving: Hole Measured Approximately 16' After Removal of Augers Backfilled with Cuttings on 9/12/2022	
2980	25								
2975	30								



THIS SUMMARY APPLIES ONLY AT THE LOCATION OF THIS BORING AND AT THE TIME OF DRILLING. SUBSURFACE CONDITIONS MAY DIFFER AT OTHER LOCATIONS AND MAY CHANGE AT THIS LOCATION WITH THE PASSAGE OF TIME. THE DATA PRESENTED IS A SIMPLIFICATION OF THE ACTUAL CONDITIONS ENCOUNTERED. THE DESCRIPTIONS PROVIDED ARE QUALITATIVE FIELD DESCRIPTIONS AND ARE NOT BASED ON QUANTITATIVE ENGINEERING ANALYSIS.

SAMPLE TYPES:	TEST TYPES:
B BULK SAMPLE	DS DIRECT SHEAR
R RING SAMPLE (CA Modified Sampler)	MD MAXIMUM DENSITY
G GRAB SAMPLE	SA SIEVE ANALYSIS
SPT STANDARD PENETRATION TEST SAMPLE	S&H SIEVE AND HYDROMETER
	EI EXPANSION INDEX
	CN CONSOLIDATION
	CR CORROSION
	AL ATTERBERG LIMITS
	CO COLLAPSE/SWELL
	RV R-VALUE
	#200 % PASSING # 200 SIEVE
GROUNDWATER TABLE	

Geotechnical Boring Log Borehole HS-5

Date: 9/12/2022	Drilling Company: Choice Drilling
Project Name: Mojave 68 - Victorville	Type of Rig: Truck Mounted
Project Number: 22124-01	Drop: 30" Hole Diameter: 6"
Elevation of Top of Hole: ~3010' MSL	Drive Weight: 140 pounds
Hole Location: See Geotechnical Map	Page 1 of 1

Elevation (ft)	Depth (ft)	Graphic Log	Sample Number	Blow Count	Dry Density (pcf)	Moisture (%)	USCS Symbol	DESCRIPTION	Type of Test
	0						SM	@ 0' - Silty SAND: reddish brown, dry	
			R-1	9 25 38	129.5	2.1		@ 2.5' - Silty SAND: reddish brown, slightly moist, dense	
3005	5	B-1	SPT-1	6 9 10		1.3	SP-SM	@ 5' - SAND with Silt: yellowish gray, dry, medium dense	
			R-2	28 40 45	113.0	1.7	SM	@ 7.5' - Silty SAND: pale brown, dry, very dense	
3000	10		SPT-2	13 16 20		4.3	ML	@ 10' - Sandy SILT: light brown, slightly moist, hard	
2995	15		R-3	39 50/6"	109.2	2.0	SM	@ 15' - Silty SAND: light brown, dry, very dense	
2990	20		SPT-3	8 10 13		2.7	ML	@ 20' - Sandy SILT: light brownish gray, slightly moist, very stiff	
								Total Depth = 21' Groundwater Not Encountered Caving: Hole Measured Approximately 18.6' After Removal of Augers Backfilled with Cuttings on 9/12/2022	
2985	25								
	30								



THIS SUMMARY APPLIES ONLY AT THE LOCATION OF THIS BORING AND AT THE TIME OF DRILLING. SUBSURFACE CONDITIONS MAY DIFFER AT OTHER LOCATIONS AND MAY CHANGE AT THIS LOCATION WITH THE PASSAGE OF TIME. THE DATA PRESENTED IS A SIMPLIFICATION OF THE ACTUAL CONDITIONS ENCOUNTERED. THE DESCRIPTIONS PROVIDED ARE QUALITATIVE FIELD DESCRIPTIONS AND ARE NOT BASED ON QUANTITATIVE ENGINEERING ANALYSIS.

SAMPLE TYPES:	TEST TYPES:
B BULK SAMPLE	DS DIRECT SHEAR
R RING SAMPLE (CA Modified Sampler)	MD MAXIMUM DENSITY
G GRAB SAMPLE	SA SIEVE ANALYSIS
SPT STANDARD PENETRATION TEST SAMPLE	S&H SIEVE AND HYDROMETER
	EI EXPANSION INDEX
	CN CONSOLIDATION
	CR CORROSION
	AL ATTERBERG LIMITS
GROUNDWATER TABLE	CO COLLAPSE/SWELL
	RV R-VALUE
	#200 % PASSING # 200 SIEVE

Geotechnical Boring Log Borehole HS-6

Date: 9/12/2022	Drilling Company: Choice Drilling
Project Name: Mojave 68 - Victorville	Type of Rig: Truck Mounted
Project Number: 22124-01	Drop: 30" Hole Diameter: 6"
Elevation of Top of Hole: ~3008' MSL	Drive Weight: 140 pounds
Hole Location: See Geotechnical Map	Page 1 of 1

Elevation (ft)	Depth (ft)	Graphic Log	Sample Number	Blow Count	Dry Density (pcf)	Moisture (%)	USCS Symbol	DESCRIPTION	Type of Test
	0	B-1					SM	@ 0' - Silty SAND: light reddish brown, dry	
3005			SPT-1	5 8		3.8		@ 2.5' - Silty SAND: light reddish brown, slightly moist, medium dense	
	5		R-1	40 50/3"	117.3	3.3		@ 5' - Silty SAND: light brown, slightly moist, very dense	
3000			SPT-2	6 9		3.3		@ 7.5' - Silty SAND: light olive brown, slightly moist, medium dense	
	10		R-2	35 50/5"	109.0	2.4		@ 10' - Silty SAND: light grayish brown, slightly moist, very dense	
2995								Total Depth = 11' Groundwater Not Encountered Caving: Hole Measured Approximately 7' After Removal of Augers Backfilled with Cuttings on 9/12/2022	
	15								
2990									
	20								
2985									
	25								
2980									
	30								



THIS SUMMARY APPLIES ONLY AT THE LOCATION OF THIS BORING AND AT THE TIME OF DRILLING. SUBSURFACE CONDITIONS MAY DIFFER AT OTHER LOCATIONS AND MAY CHANGE AT THIS LOCATION WITH THE PASSAGE OF TIME. THE DATA PRESENTED IS A SIMPLIFICATION OF THE ACTUAL CONDITIONS ENCOUNTERED. THE DESCRIPTIONS PROVIDED ARE QUALITATIVE FIELD DESCRIPTIONS AND ARE NOT BASED ON QUANTITATIVE ENGINEERING ANALYSIS.

SAMPLE TYPES:	TEST TYPES:
B BULK SAMPLE	DS DIRECT SHEAR
R RING SAMPLE (CA Modified Sampler)	MD MAXIMUM DENSITY
G GRAB SAMPLE	SA SIEVE ANALYSIS
SPT STANDARD PENETRATION TEST SAMPLE	S&H SIEVE AND HYDROMETER
	EI EXPANSION INDEX
	CN CONSOLIDATION
	CR CORROSION
	AL ATTERBERG LIMITS
GROUNDWATER TABLE	CO COLLAPSE/SWELL
	RV R-VALUE
	#200 % PASSING # 200 SIEVE

Geotechnical Boring Log Borehole HS-7

Date: 9/13/2022	Drilling Company: Choice Drilling
Project Name: Mojave 68 - Victorville	Type of Rig: Truck Mounted
Project Number: 22124-01	Drop: 30" Hole Diameter: 6"
Elevation of Top of Hole: ~3014' MSL	Drive Weight: 140 pounds
Hole Location: See Geotechnical Map	Page 1 of 2

Elevation (ft)	Depth (ft)	Graphic Log	Sample Number	Blow Count	Dry Density (pcf)	Moisture (%)	USCS Symbol	DESCRIPTION	Type of Test
3015	0						SM	@ 0' - Silty SAND: light brown, dry	EI
			R-1	12 18 39	120.1	2.3		@ 2.5' - Silty SAND: light brown, slightly moist, dense	
3010	5	B-1	SPT-1	7 9 12		3.1		@ 5' - Silty SAND: grayish brown, slightly moist, medium dense	SA
			R-2	28 45 50/5"	121.1	4.1		@ 7.5' - Silty SAND: grayish brown, slightly moist, very dense	
3005	10		SPT-2	7 10 13		3.7		@ 10' - Silty SAND: light brown, slightly moist, medium dense	SA
3000	15		R-3	26 40 50/5"	117.4	1.0	SP-SM	@ 15' - SAND with Silt: olive gray, dry, very dense	
2995	20		SPT-3	15 18 30		9.0	SM	@ 20' - Silty SAND: olive brown, moist, very dense	
2990	25		R-4	38 50/5"	120.8	3.6		@ 25' - Silty SAND: light olive, slightly moist, very dense	
	30								



THIS SUMMARY APPLIES ONLY AT THE LOCATION OF THIS BORING AND AT THE TIME OF DRILLING. SUBSURFACE CONDITIONS MAY DIFFER AT OTHER LOCATIONS AND MAY CHANGE AT THIS LOCATION WITH THE PASSAGE OF TIME. THE DATA PRESENTED IS A SIMPLIFICATION OF THE ACTUAL CONDITIONS ENCOUNTERED. THE DESCRIPTIONS PROVIDED ARE QUALITATIVE FIELD DESCRIPTIONS AND ARE NOT BASED ON QUANTITATIVE ENGINEERING ANALYSIS.

SAMPLE TYPES:	TEST TYPES:
B BULK SAMPLE	DS DIRECT SHEAR
R RING SAMPLE (CA Modified Sampler)	MD MAXIMUM DENSITY
G GRAB SAMPLE	SA SIEVE ANALYSIS
SPT STANDARD PENETRATION TEST SAMPLE	S&H SIEVE AND HYDROMETER
	EI EXPANSION INDEX
	CN CONSOLIDATION
	CR CORROSION
	AL ATTERBERG LIMITS
	CO COLLAPSE/SWELL
	RV R-VALUE
	#200 % PASSING # 200 SIEVE



Geotechnical Boring Log Borehole HS-7

Date: 9/13/2022	Drilling Company: Choice Drilling
Project Name: Mojave 68 - Victorville	Type of Rig: Truck Mounted
Project Number: 22124-01	Drop: 30" Hole Diameter: 6"
Elevation of Top of Hole: ~3014' MSL	Drive Weight: 140 pounds
Hole Location: See Geotechnical Map	Page 2 of 2

Elevation (ft)	Depth (ft)	Graphic Log	Sample Number	Blow Count	Dry Density (pcf)	Moisture (%)	USCS Symbol	DESCRIPTION	Type of Test
2985	30		SPT-4	13 16 20		8.8	ML	@ 30' - Sandy SILT: light brown, moist, dense	
2980	35		R-5	29 44 50/3"	105.2	4.2		@ 35' - Sandy SILT: light yellowish brown, slightly moist, hard	
2975	40		SPT-5	20 32 40		12.3		@ 40' - SILT: grayish brown, moist, hard	
2970	45		R-6	50/5"	101.7	3.8	SM	@ 45' - Silty SAND: pale brown, slightly moist, very dense	
2965	50		SPT-6	20 38 50/5"		12.6	ML	@ 50' - SILT: grayish brown, moist, hard	
2960	55							Total Depth = 51' Groundwater Not Encountered Caving: Hole Measured Approximately 48' After Removal of Augers Backfilled with Cuttings on 9/13/2022	



THIS SUMMARY APPLIES ONLY AT THE LOCATION OF THIS BORING AND AT THE TIME OF DRILLING. SUBSURFACE CONDITIONS MAY DIFFER AT OTHER LOCATIONS AND MAY CHANGE AT THIS LOCATION WITH THE PASSAGE OF TIME. THE DATA PRESENTED IS A SIMPLIFICATION OF THE ACTUAL CONDITIONS ENCOUNTERED. THE DESCRIPTIONS PROVIDED ARE QUALITATIVE FIELD DESCRIPTIONS AND ARE NOT BASED ON QUANTITATIVE ENGINEERING ANALYSIS.

<p>SAMPLE TYPES:</p> <p>B BULK SAMPLE R RING SAMPLE (CA Modified Sampler) G GRAB SAMPLE SPT STANDARD PENETRATION TEST SAMPLE</p> <p> GROUNDWATER TABLE</p>	<p>TEST TYPES:</p> <p>DS DIRECT SHEAR MD MAXIMUM DENSITY SA SIEVE ANALYSIS S&H SIEVE AND HYDROMETER EI EXPANSION INDEX CN CONSOLIDATION CR CORROSION AL ATTERBERG LIMITS CO COLLAPSE/SWELL RV R-VALUE #200 % PASSING # 200 SIEVE</p>
---	---

Geotechnical Boring Log Borehole HS-8

Date: 9/13/2022	Drilling Company: Choice Drilling
Project Name: Mojave 68 - Victorville	Type of Rig: Truck Mounted
Project Number: 22124-01	Drop: 30" Hole Diameter: 6"
Elevation of Top of Hole: ~3014' MSL	Drive Weight: 140 pounds
Hole Location: See Geotechnical Map	Page 1 of 1

Elevation (ft)	Depth (ft)	Graphic Log	Sample Number	Blow Count	Dry Density (pcf)	Moisture (%)	USCS Symbol	DESCRIPTION	Type of Test
	0						SM	@ 0' - Silty SAND: yellowish brown, dry	
3010	5	SPT-1 B-1		7 9 10		2.5		@ 2.5' - Silty SAND: yellowish brown, slightly moist, medium dense	
			R-1	32 50/5"	119.8	2.1		@ 5' - Silty SAND: light brown, slightly moist, very dense	
3005	10	SPT-2		14 19 29		4.6		@ 7.5' - Silty SAND: light olive gray, slightly moist, very dense	
			R-2	39 50/6"	117.4	2.5		@ 10' - Silty SAND: light yellowish brown, slightly moist, very dense	
3000	15							Total Depth = 11' Groundwater Not Encountered Caving: Hole Measured Approximately 8.8' After Removal of Augers Backfilled with Cuttings on 9/13/2022	
2995	20								
2990	25								
2985	30								



THIS SUMMARY APPLIES ONLY AT THE LOCATION OF THIS BORING AND AT THE TIME OF DRILLING. SUBSURFACE CONDITIONS MAY DIFFER AT OTHER LOCATIONS AND MAY CHANGE AT THIS LOCATION WITH THE PASSAGE OF TIME. THE DATA PRESENTED IS A SIMPLIFICATION OF THE ACTUAL CONDITIONS ENCOUNTERED. THE DESCRIPTIONS PROVIDED ARE QUALITATIVE FIELD DESCRIPTIONS AND ARE NOT BASED ON QUANTITATIVE ENGINEERING ANALYSIS.

<p>SAMPLE TYPES:</p> <p>B BULK SAMPLE R RING SAMPLE (CA Modified Sampler) G GRAB SAMPLE SPT STANDARD PENETRATION TEST SAMPLE</p> <p style="text-align: center;">≡</p> <p>GROUNDWATER TABLE</p>	<p>TEST TYPES:</p> <p>DS DIRECT SHEAR MD MAXIMUM DENSITY SA SIEVE ANALYSIS S&H SIEVE AND HYDROMETER EI EXPANSION INDEX CN CONSOLIDATION CR CORROSION AL ATTERBERG LIMITS CO COLLAPSE/SWELL RV R-VALUE #200 % PASSING # 200 SIEVE</p>
--	---

Geotechnical Boring Log Borehole HS-9

Date: 9/13/2022	Drilling Company: Choice Drilling
Project Name: Mojave 68 - Victorville	Type of Rig: Truck Mounted
Project Number: 22124-01	Drop: 30" Hole Diameter: 6"
Elevation of Top of Hole: ~3003' MSL	Drive Weight: 140 pounds
Hole Location: See Geotechnical Map	Page 1 of 1

Elevation (ft)	Depth (ft)	Graphic Log	Sample Number	Blow Count	Dry Density (pcf)	Moisture (%)	USCS Symbol	DESCRIPTION	Type of Test
3000	0						ML	@ 0' - Sandy SILT: light brown, dry	
			R-1	28 40 50/5"	105.0	6.4		@ 2.5' - Sandy SILT: light brown, moist, hard	
	5	B-1	SPT-1	5 6 9		3.4	SM	@ 5' - Silty SAND: gray, slightly moist, medium dense	#200
2995			R-2	18 26 38	113.3	2.7		@ 7.5' - Silty SAND: olive gray, dry, very dense	CN
	10		SPT-2	7 9 12		2.7		@ 10' - Silty SAND: light yellowish brown, slightly moist, medium dense	#200
2990									
	15		R-3	30 39 50	117.7	10.0	ML	@ 15' - Silty SAND: light grayish brown, moist to very moist, hard	
2985									
	20		SPT-3	8 9 15		1.5	SP-SM	@ 20' - SAND with Silt: gray, dry, dense	
2980								Total Depth = 21' Groundwater Not Encountered Caving: Hole Measured Approximately 18.3' After Removal of Augers Backfilled with Cuttings on 9/13/2022	
	25								
2975									
	30								



THIS SUMMARY APPLIES ONLY AT THE LOCATION OF THIS BORING AND AT THE TIME OF DRILLING. SUBSURFACE CONDITIONS MAY DIFFER AT OTHER LOCATIONS AND MAY CHANGE AT THIS LOCATION WITH THE PASSAGE OF TIME. THE DATA PRESENTED IS A SIMPLIFICATION OF THE ACTUAL CONDITIONS ENCOUNTERED. THE DESCRIPTIONS PROVIDED ARE QUALITATIVE FIELD DESCRIPTIONS AND ARE NOT BASED ON QUANTITATIVE ENGINEERING ANALYSIS.

SAMPLE TYPES: B BULK SAMPLE R RING SAMPLE (CA Modified Sampler) G GRAB SAMPLE SPT STANDARD PENETRATION TEST SAMPLE GROUNDWATER TABLE	TEST TYPES: DS DIRECT SHEAR MD MAXIMUM DENSITY SA SIEVE ANALYSIS S&H SIEVE AND HYDROMETER EI EXPANSION INDEX CN CONSOLIDATION CR CORROSION AL ATTERBERG LIMITS CO COLLAPSE/SWELL RV R-VALUE #200 % PASSING # 200 SIEVE
--	--

Geotechnical Boring Log Borehole HS-10

Date: 9/13/2022	Drilling Company: Choice Drilling
Project Name: Mojave 68 - Victorville	Type of Rig: Truck Mounted
Project Number: 22124-01	Drop: 30" Hole Diameter: 6"
Elevation of Top of Hole: ~3013' MSL	Drive Weight: 140 pounds
Hole Location: See Geotechnical Map	Page 1 of 1

Elevation (ft)	Depth (ft)	Graphic Log	Sample Number	Blow Count	Dry Density (pcf)	Moisture (%)	USCS Symbol	DESCRIPTION	Type of Test
	0						SM	@ 0' - Silty SAND: light brown, dry	
3010			SPT-1	5 6 7		1.8		@ 2.5' - Silty SAND: light brown, dry, medium dense	
	5	B-1	R-1	20 29 40	112.5	1.8		@ 5' - Silty SAND: light yellowish brown, dry, very dense	
3000			SPT-2	20 32 40		4.5		@ 7.5' - Silty SAND: light brown, slightly moist, very dense	
	10		R-2	48 50/3"	116.2	6.8		@ 10' - Silty SAND: light brown, moist, very dense	
2995								Total Depth = 11' Groundwater Not Encountered Backfilled with Cuttings on 9/13/2022	
	15								
2990									
	20								
2985									
	25								
2980									
	30								



THIS SUMMARY APPLIES ONLY AT THE LOCATION OF THIS BORING AND AT THE TIME OF DRILLING. SUBSURFACE CONDITIONS MAY DIFFER AT OTHER LOCATIONS AND MAY CHANGE AT THIS LOCATION WITH THE PASSAGE OF TIME. THE DATA PRESENTED IS A SIMPLIFICATION OF THE ACTUAL CONDITIONS ENCOUNTERED. THE DESCRIPTIONS PROVIDED ARE QUALITATIVE FIELD DESCRIPTIONS AND ARE NOT BASED ON QUANTITATIVE ENGINEERING ANALYSIS.

SAMPLE TYPES:	TEST TYPES:
B BULK SAMPLE	DS DIRECT SHEAR
R RING SAMPLE (CA Modified Sampler)	MD MAXIMUM DENSITY
G GRAB SAMPLE	SA SIEVE ANALYSIS
SPT STANDARD PENETRATION TEST SAMPLE	S&H SIEVE AND HYDROMETER
	EI EXPANSION INDEX
	CN CONSOLIDATION
	CR CORROSION
	AL ATTERBERG LIMITS
GROUNDWATER TABLE	CO COLLAPSE/SWELL
	RV R-VALUE
	#200 % PASSING # 200 SIEVE

Geotechnical Boring Log Borehole HS-11

Date: 9/13/2022	Drilling Company: Choice Drilling
Project Name: Mojave 68 - Victorville	Type of Rig: Truck Mounted
Project Number: 22124-01	Drop: 30" Hole Diameter: 6"
Elevation of Top of Hole: ~3010' MSL	Drive Weight: 140 pounds
Hole Location: See Geotechnical Map	Page 1 of 1

Elevation (ft)	Depth (ft)	Graphic Log	Sample Number	Blow Count	Dry Density (pcf)	Moisture (%)	USCS Symbol	DESCRIPTION	Type of Test
	0						ML	@ 0' - Sandy SILT: light yellowish brown, slightly moist	
			R-1	12 15 21	101.5	7.5		@ 2.5' - Sandy SILT: light yellowish brown, slightly moist, very stiff	
3005	5	B-1	SPT-1	5 6 9		2.0	SM	@ 5' - Silty SAND: light olive gray, dry, medium dense	
			R-2	33 50/6"	124.6	6.4		@ 7.5' - Silty SAND: brown, slightly moist, very dense	
3000	10		SPT-2	15 19 30		6.1	ML	@ 10' - Sandy SILT: light brown, slightly moist, hard	
2995	15		R-3	40 50/5"	124.2	1.2	SP-SM	@ 15' - SAND with Silt: light brown, dry, very dense	CN
2990	20		SPT-3	10 11 15		2.9	SM	@ 20' - Silty SAND: gray, slightly moist, dense	#200
								Total Depth = 21' Groundwater Not Encountered Caving: Hole Measured Approximately 18.3' After Removal of Augers Backfilled with Cuttings on 9/13/2022	
2985	25								
	30								



THIS SUMMARY APPLIES ONLY AT THE LOCATION OF THIS BORING AND AT THE TIME OF DRILLING. SUBSURFACE CONDITIONS MAY DIFFER AT OTHER LOCATIONS AND MAY CHANGE AT THIS LOCATION WITH THE PASSAGE OF TIME. THE DATA PRESENTED IS A SIMPLIFICATION OF THE ACTUAL CONDITIONS ENCOUNTERED. THE DESCRIPTIONS PROVIDED ARE QUALITATIVE FIELD DESCRIPTIONS AND ARE NOT BASED ON QUANTITATIVE ENGINEERING ANALYSIS.

SAMPLE TYPES:	TEST TYPES:
B BULK SAMPLE	DS DIRECT SHEAR
R RING SAMPLE (CA Modified Sampler)	MD MAXIMUM DENSITY
G GRAB SAMPLE	SA SIEVE ANALYSIS
SPT STANDARD PENETRATION TEST SAMPLE	S&H SIEVE AND HYDROMETER
	EI EXPANSION INDEX
	CN CONSOLIDATION
	CR CORROSION
	AL ATTERBERG LIMITS
GROUNDWATER TABLE	CO COLLAPSE/SWELL
	RV R-VALUE
	#200 % PASSING # 200 SIEVE

Geotechnical Boring Log Borehole HS-12

Date: 9/13/2022	Drilling Company: Choice Drilling
Project Name: Mojave 68 - Victorville	Type of Rig: Truck Mounted
Project Number: 22124-01	Drop: 30" Hole Diameter: 6"
Elevation of Top of Hole: ~3003' MSL	Drive Weight: 140 pounds
Hole Location: See Geotechnical Map	Page 1 of 1

Elevation (ft)	Depth (ft)	Graphic Log	Sample Number	Blow Count	Dry Density (pcf)	Moisture (%)	USCS Symbol	DESCRIPTION	Type of Test
	0						ML	@ 0' - Sandy SILT: light brown, dry	
3000			SPT-1	12 15 21		4.3		@ 2.5' - Sandy SILT: light brown, slightly moist, hard	
	5	B-1	R-1	28 40 50/6"	114.4	3.8	SM	@ 5' - Silty SAND: light yellowish brown, slightly moist, very dense	
2995			SPT-2	10 12 16		2.7		@ 7.5' - Silty SAND: light yellowish brown, slightly moist, dense	
	10		R-2	39 50/5"	126.1	3.2		@ 10' - Silty SAND: brown, slightly moist, very dense	
2990								Total Depth = 11' Groundwater Not Encountered Caving: Hole Measured Approximately 7' After Removal of Augers Backfilled with Cuttings on 9/13/2022	
	15								
2985									
	20								
2980									
	25								
2975									
	30								



THIS SUMMARY APPLIES ONLY AT THE LOCATION OF THIS BORING AND AT THE TIME OF DRILLING. SUBSURFACE CONDITIONS MAY DIFFER AT OTHER LOCATIONS AND MAY CHANGE AT THIS LOCATION WITH THE PASSAGE OF TIME. THE DATA PRESENTED IS A SIMPLIFICATION OF THE ACTUAL CONDITIONS ENCOUNTERED. THE DESCRIPTIONS PROVIDED ARE QUALITATIVE FIELD DESCRIPTIONS AND ARE NOT BASED ON QUANTITATIVE ENGINEERING ANALYSIS.

SAMPLE TYPES:	TEST TYPES:
B BULK SAMPLE	DS DIRECT SHEAR
R RING SAMPLE (CA Modified Sampler)	MD MAXIMUM DENSITY
G GRAB SAMPLE	SA SIEVE ANALYSIS
SPT STANDARD PENETRATION TEST SAMPLE	S&H SIEVE AND HYDROMETER
	EI EXPANSION INDEX
	CN CONSOLIDATION
	CR CORROSION
	AL ATTERBERG LIMITS
GROUNDWATER TABLE	CO COLLAPSE/SWELL
	RV R-VALUE
	#200 % PASSING # 200 SIEVE

Geotechnical Boring Log Borehole I-1

Date: 9/12/2022	Drilling Company: Choice Drilling
Project Name: Mojave 68 - Victorville	Type of Rig: Truck Mounted
Project Number: 22124-01	Drop: 30" Hole Diameter: 8"
Elevation of Top of Hole: ~2995' MSL	Drive Weight: 140 pounds
Hole Location: See Geotechnical Map	Page 1 of 1

Elevation (ft)	Depth (ft)	Graphic Log	Sample Number	Blow Count	Dry Density (pcf)	Moisture (%)	USCS Symbol	DESCRIPTION	Type of Test
	0						SM	@ 0' - Silty SAND: light reddish brown, dry	
			SPT-1	4 5		1.4		@ 2.5' - Silty SAND: light reddish brown, dry, medium dense	
2990	5		SPT-2	7 9 12		1.0	SP-SM	@ 5' - SAND with Silt: light brown, dry, medium dense	
2985	10								
2980	15							Total Depth = 11' Groundwater Not Encountered 3" Perforated Pipe with Filter Sock Installed Surrounded by Sand, and Presoaked on 9/12/22 Pipe Removed and Boring Backfilled with Cuttings on 9/13/2022	
2975	20								
2970	25								
2965	30								



THIS SUMMARY APPLIES ONLY AT THE LOCATION OF THIS BORING AND AT THE TIME OF DRILLING. SUBSURFACE CONDITIONS MAY DIFFER AT OTHER LOCATIONS AND MAY CHANGE AT THIS LOCATION WITH THE PASSAGE OF TIME. THE DATA PRESENTED IS A SIMPLIFICATION OF THE ACTUAL CONDITIONS ENCOUNTERED. THE DESCRIPTIONS PROVIDED ARE QUALITATIVE FIELD DESCRIPTIONS AND ARE NOT BASED ON QUANTITATIVE ENGINEERING ANALYSIS.

SAMPLE TYPES:	TEST TYPES:
B BULK SAMPLE	DS DIRECT SHEAR
R RING SAMPLE (CA Modified Sampler)	MD MAXIMUM DENSITY
G GRAB SAMPLE	SA SIEVE ANALYSIS
SPT STANDARD PENETRATION TEST SAMPLE	S&H SIEVE AND HYDROMETER
	EI EXPANSION INDEX
	CN CONSOLIDATION
	CR CORROSION
	AL ATTERBERG LIMITS
GROUNDWATER TABLE	CO COLLAPSE/SWELL
	RV R-VALUE
	#200 % PASSING # 200 SIEVE

Geotechnical Boring Log Borehole I-2

Date: 9/12/2022	Drilling Company: Choice Drilling
Project Name: Mojave 68 - Victorville	Type of Rig: Truck Mounted
Project Number: 22124-01	Drop: 30" Hole Diameter: 8"
Elevation of Top of Hole: ~2995' MSL	Drive Weight: 140 pounds
Hole Location: See Geotechnical Map	Page 1 of 1

Elevation (ft)	Depth (ft)	Graphic Log	Sample Number	Blow Count	Dry Density (pcf)	Moisture (%)	USCS Symbol	DESCRIPTION	Type of Test
	0							@ 0' - Sandy CLAY: reddish brown, dry	
			SPT-1	6 15		6.6	CL	@ 2.5' - Sandy CLAY, reddish brown, slightly moist, very stiff	
2990	5		SPT-2	6 12		2.8	SM	@ 5' - Silty SAND: yellowish brown, slightly moist, medium dense	
			SPT-3	8 12 15		3.6	SM-ML	@ 7.5' - Silty SAND/Sandy SILT: light brown, slightly moist, dense/hard	
2985	10								
								Total Depth = 11' Groundwater Not Encountered 3" Perforated Pipe with Filter Sock Installed Surrounded by Sand, and Presoaked on 9/12/22 Pipe Removed and Boring Backfilled with Cuttings on 9/13/2022	
2980	15								
2975	20								
2970	25								
2965	30								



THIS SUMMARY APPLIES ONLY AT THE LOCATION OF THIS BORING AND AT THE TIME OF DRILLING. SUBSURFACE CONDITIONS MAY DIFFER AT OTHER LOCATIONS AND MAY CHANGE AT THIS LOCATION WITH THE PASSAGE OF TIME. THE DATA PRESENTED IS A SIMPLIFICATION OF THE ACTUAL CONDITIONS ENCOUNTERED. THE DESCRIPTIONS PROVIDED ARE QUALITATIVE FIELD DESCRIPTIONS AND ARE NOT BASED ON QUANTITATIVE ENGINEERING ANALYSIS.

SAMPLE TYPES:
 B BULK SAMPLE
 R RING SAMPLE (CA Modified Sampler)
 G GRAB SAMPLE
 SPT STANDARD PENETRATION TEST SAMPLE

GROUNDWATER TABLE

TEST TYPES:
 DS DIRECT SHEAR
 MD MAXIMUM DENSITY
 SA SIEVE ANALYSIS
 S&H SIEVE AND HYDROMETER
 EI EXPANSION INDEX
 CN CONSOLIDATION
 CR CORROSION
 AL ATTERBERG LIMITS
 CO COLLAPSE/SWELL
 RV R-VALUE
 #200 % PASSING # 200 SIEVE

Appendix C
Laboratory Test Results

APPENDIX C

Laboratory Test Results

The laboratory testing program was directed towards providing quantitative data relating to the relevant engineering properties of the soils. Samples considered representative of site conditions were tested in general accordance with American Society for Testing and Materials (ASTM) procedure and/or California Test Methods (CTM), where applicable. The following summary is a brief outline of the test type and a table summarizing the test results.

Moisture and Density Determination Tests: Moisture content (ASTM D2216) and dry density determinations (ASTM D2937) were performed on driven samples obtained from the test borings. The results of these tests are presented in the boring logs. Where applicable, only moisture content was determined from undisturbed or disturbed samples.

Grain Size Distribution/Fines Content: Representative samples were dried, weighed, and soaked in water until individual soil particles were separated (per ASTM D421) and then washed on a No. 200 sieve (ASTM D1140). Where applicable, the portion retained on the No. 200 sieve was dried and then sieved on a U.S. Standard brass sieve set in accordance with ASTM D6913 (sieve).

Sample Location	Description	% Passing # 200 Sieve
HS-1 @ 10 ft	Silty Sand	48
HS-2 @ 7.5 ft	Silty Sand	24
HS-2 @ 15 ft	Clayey Sand	24
HS-2 @ 25 ft	Silty, Clayey Sand	45
HS-7 @ 5 ft	Silty Sand	25
HS-7 @ 10 ft	Silty Sand	25
HS-9 @ 5 ft	Silty Sand	34
HS-9 @ 10 ft	Silty Sand	28
HS-11 @ 20 ft	Silty Sand	49

APPENDIX C (Cont'd)

Laboratory Test Results

ASTM D4318 for engineering classification of fine-grained material and presented in the table below. The USCS soil classification indicated in the table below is based on the portion of sample passing the No. 40 sieve and may not necessarily be representative of the entire sample. The plot is provided in this Appendix.

Sample Location	Liquid Limit (%)	Plastic Limit (%)	Plasticity Index (%)	USCS Soil Classification (Passing No. 40 Sieve Only)
HS-2 @ 25 ft	24	17	7	CL-ML

Expansion Index: The expansion potential of selected representative samples was evaluated by the Expansion Index Test per ASTM D4829. The results are presented in the table below.

Sample Location	Expansion Index	Expansion Potential*
HS-2 @ 0-5 ft	18	Very Low
HS-7 @ 0-5 ft	1	Very Low

* Per ASTM D4829

Consolidation: Consolidation tests were performed per ASTM D2435. Samples (2.4 inches in diameter and 1 inch in height) were placed in a consolidometer and increasing loads were applied. The samples were allowed to consolidate under “double drainage” and total deformation for each loading step was recorded. The percent consolidation for each load step was recorded as the ratio of the amount of vertical compression to the original sample height. The consolidation pressure curves are provided in this Appendix.

Laboratory Compaction: The maximum dry density and optimum moisture content of typical materials were determined in accordance with ASTM D1557. The results are presented in the table below.

Sample Location	Sample Description	Maximum Dry Density (pcf)	Optimum Moisture Content (%)
HS-4 @ 0-5 ft	Light Brown Silty Sand	129.5	9.0

APPENDIX C (Cont'd)

Laboratory Test Results

R-value Test: R-value test was performed in general accordance with California Test Method 301. The plot is attached.

Sample No.	R-Value
HS-3 @ 0-5 ft	27

Soluble Sulfates: The soluble sulfate contents of selected samples were determined by standard geochemical methods (CTM 417). The test results are presented in the table below.

Sample Location	Sulfate Content (ppm)	Sulfate Content (%)
HS-2 @ 0-5 ft	112	< 0.02
HS-7 @ 0-5 ft	129	< 0.02

Chloride Content: Chloride content was tested per CTM 422. The results are presented below.

Sample Location	Chloride Content (ppm)
HS-2 @ 0-5 ft	21

Minimum Resistivity and pH Tests: Minimum resistivity and pH tests were performed in general accordance with CTM 643 and standard geochemical methods. The results are presented in the table below.

Sample Location	pH	Minimum Resistivity (ohms-cm)
HS-2 @ 0-5 ft	8.6	2,950

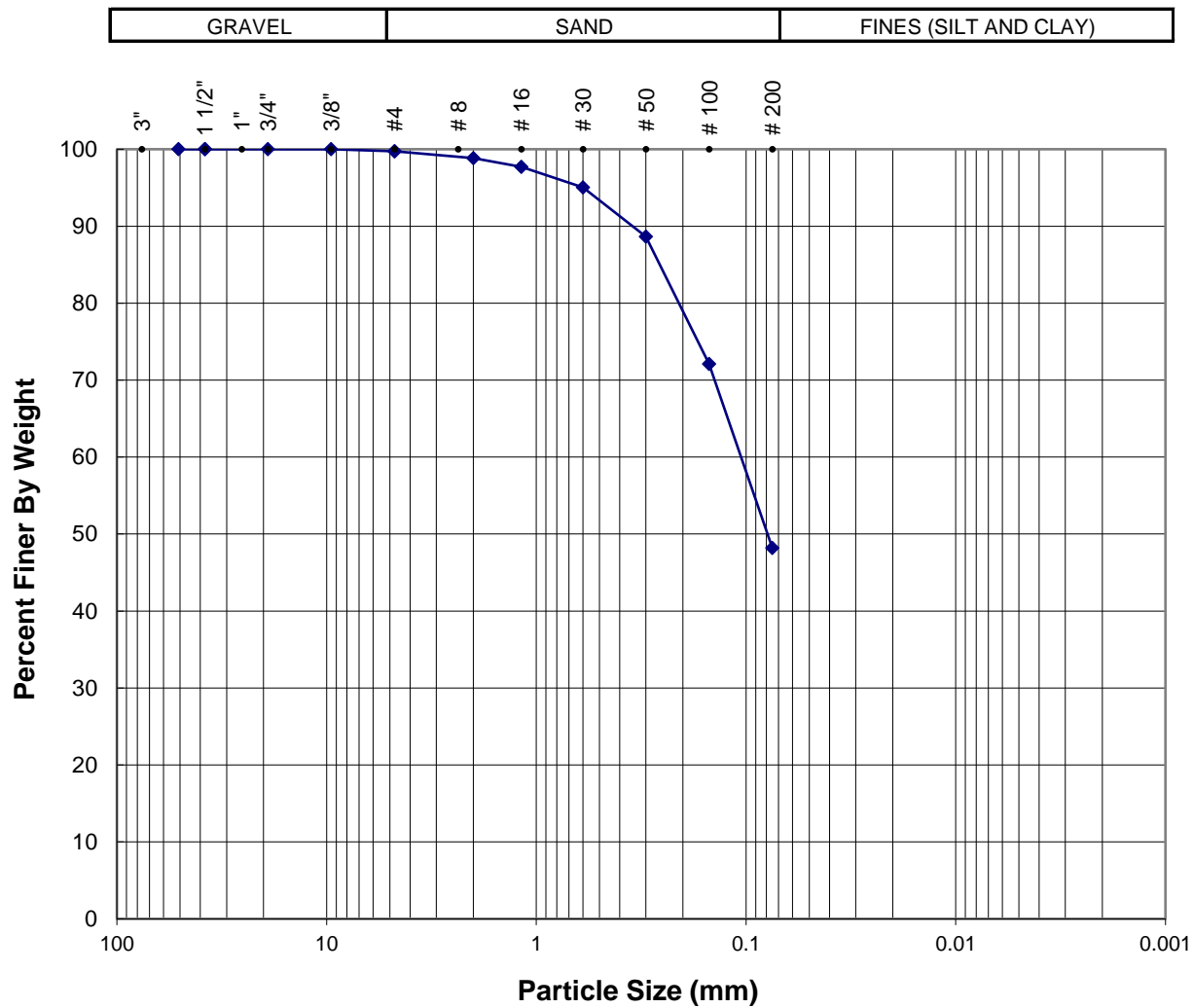

Location:	Sample No.:	Depth (ft.)	Soil Type	Gravel (%)	Sand (%)	Fines (%)
HS-1	SPT-2	10'	SM	0	52	48

Sample Description: Light brown silty SAND



PARTICLE SIZE ANALYSIS
(ASTM D 422)

Project Number: 22124-01
Date: Sep-22

Mojave 68, Victorville

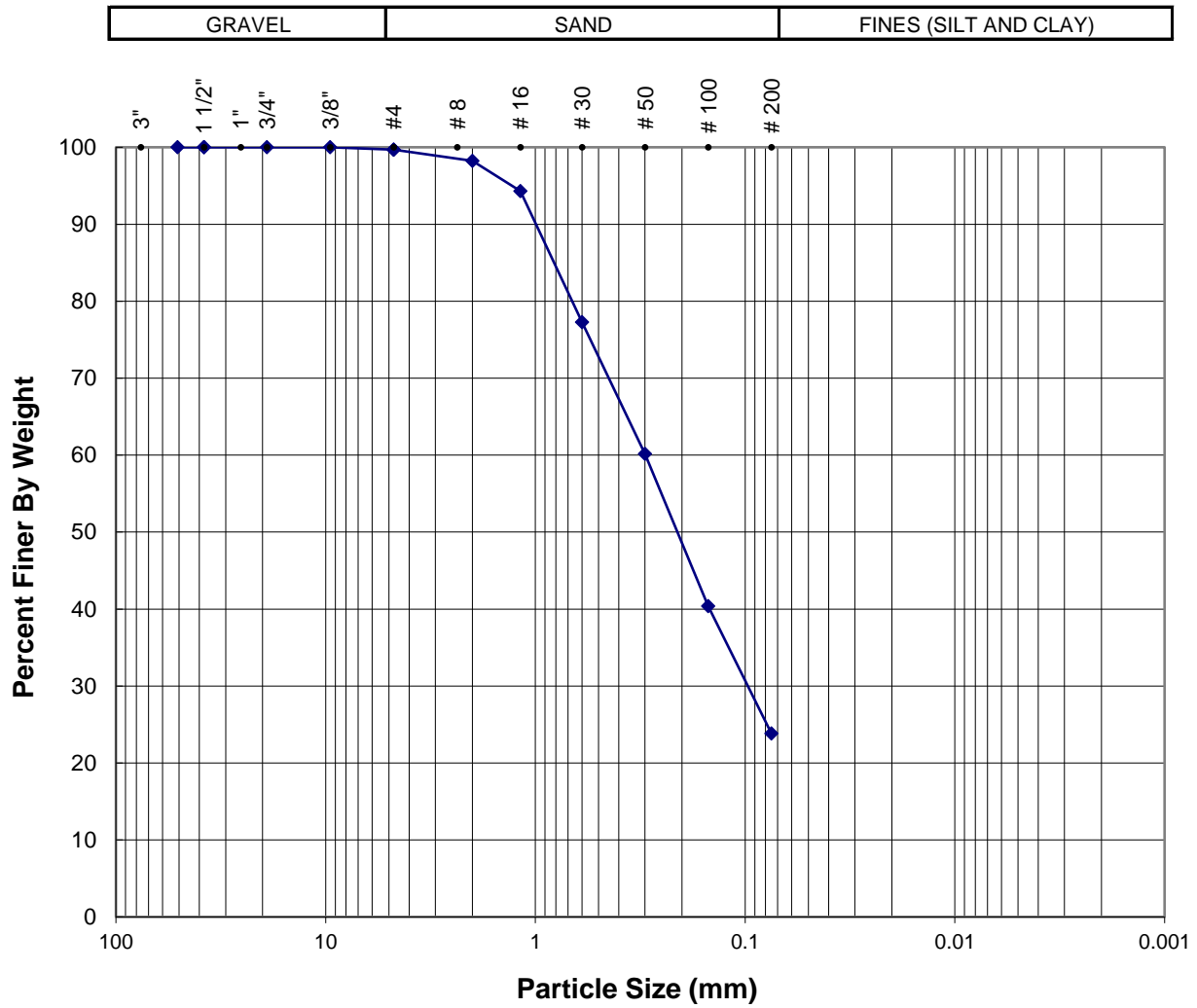

Location:	Sample No.:	Depth (ft.)	Soil Type	Gravel (%)	Sand (%)	Fines (%)
HS-2	SPT-2	7.5'	SM	0	76	24

Sample Description: Light brown silty SAND



PARTICLE SIZE ANALYSIS
(ASTM D 422)

Project Number: 22124-01
Date: Sep-22

Mojave 68, Victorville

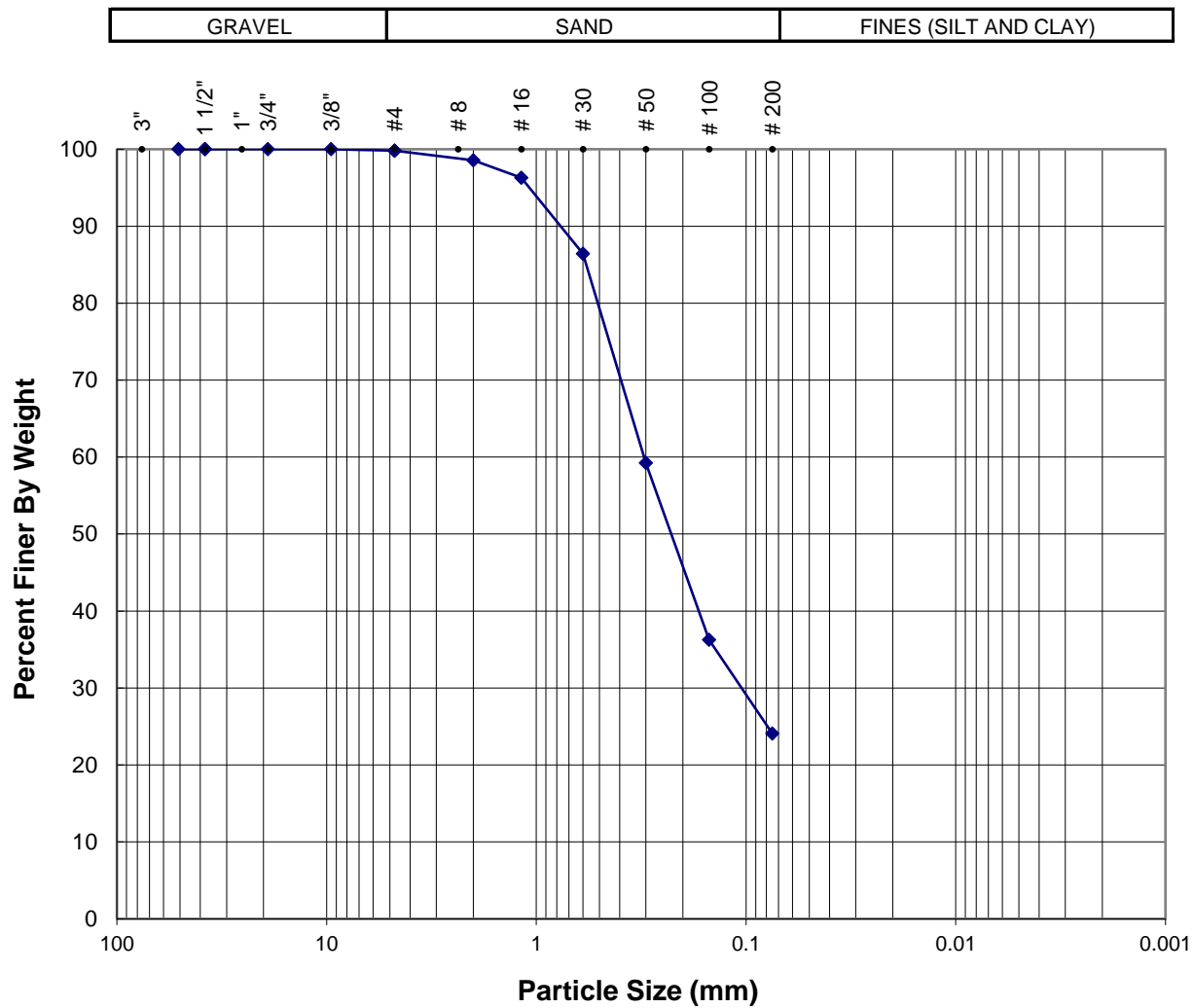

Location:	Sample No.:	Depth (ft.)	Soil Type	Gravel (%)	Sand (%)	Fines (%)
HS-2	SPT-3	15'	SC	0	76	24

Sample Description: Yellowish brown clayey SAND



PARTICLE SIZE ANALYSIS
(ASTM D 422)

Project Number: 22124-01
Date: Sep-22

Mojave 68, Victorville

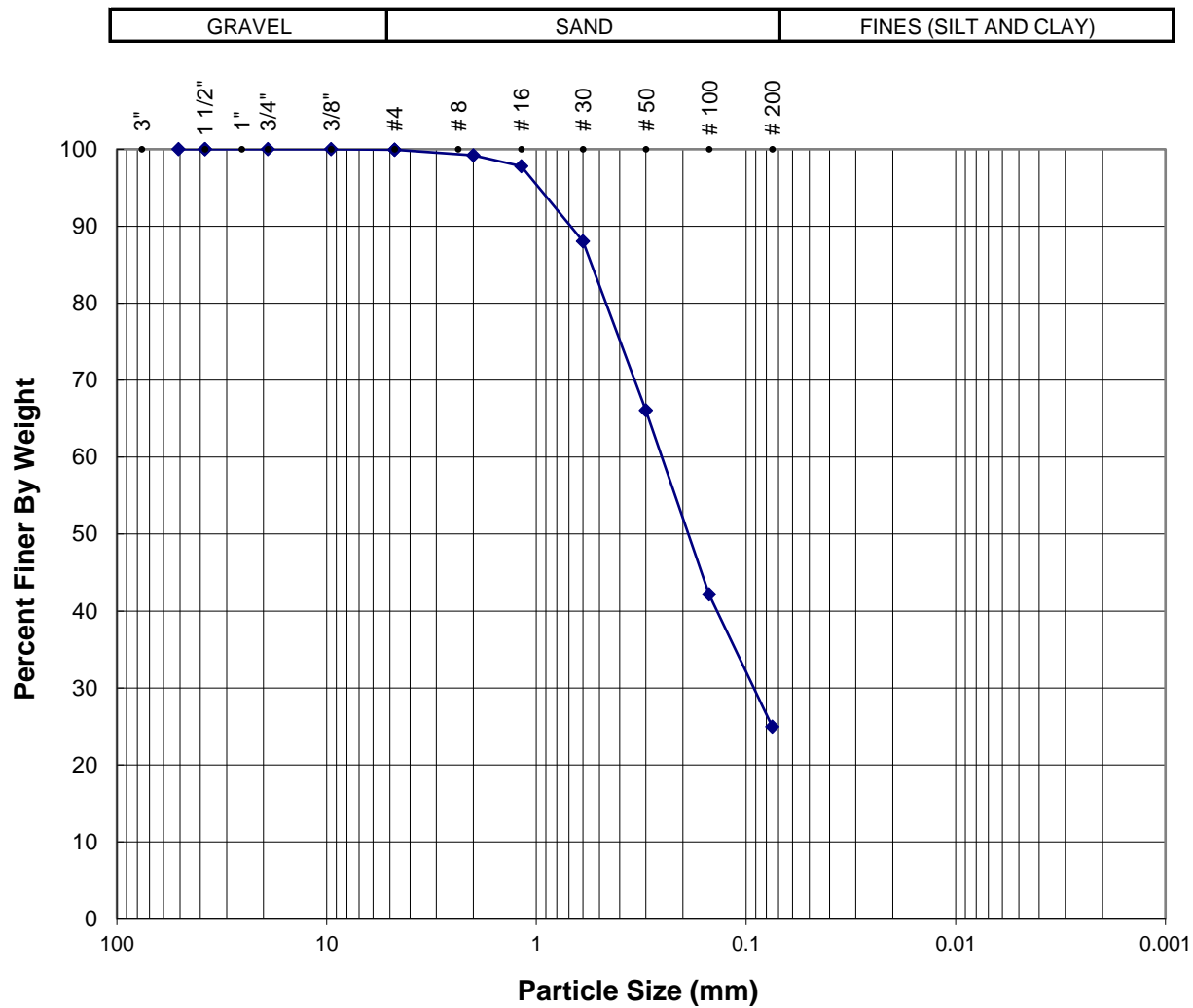

Location:	Sample No.:	Depth (ft.)	Soil Type	Gravel (%)	Sand (%)	Fines (%)
HS-7	SPT-1	5'	SM	0	75	25

Sample Description: Grayish brown silty SAND



PARTICLE SIZE ANALYSIS
(ASTM D 422)

Project Number: 22124-01
Date: Sep-22

Mojave 68, Victorville

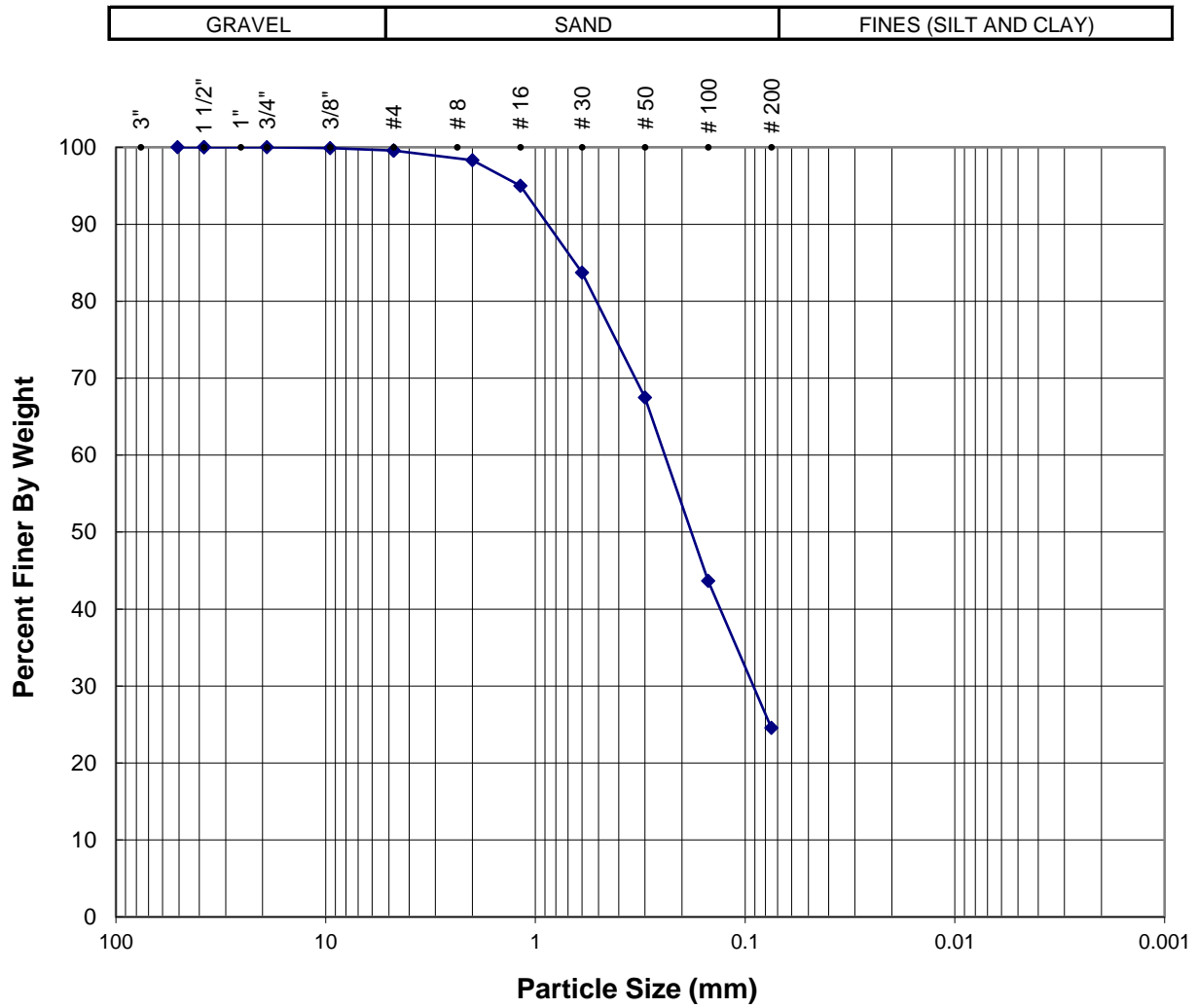

Location:	Sample No.:	Depth (ft.)	Soil Type	Gravel (%)	Sand (%)	Fines (%)
HS-7	SPT-2	10'	SM	0	75	25

Sample Description: Pale brown silty SAND



PARTICLE SIZE ANALYSIS
(ASTM D 422)

Project Number: 22124-01
Date: Sep-22

Mojave 68, Victorville

PLASTICITY CHART - CLASSIFICATION OF FINE-GRAINED SOILS

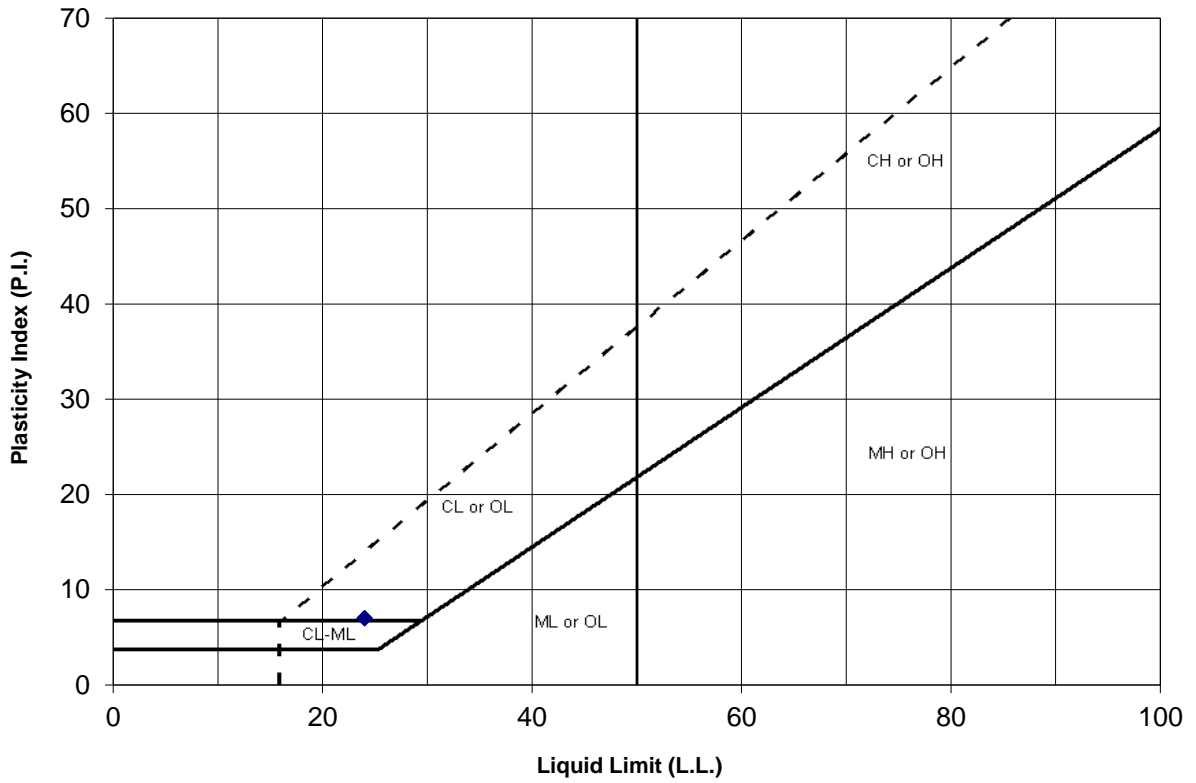

Symbol	Location.:	Sample No.:	Depth (ft)	Passing No. 200 Sieve (%)	Liquid Limit (%) LL	Plastic Limit (%) PL	Plasticity Index (%) PI	USCS
◆	HS-2	SPT-4	25'	45	24	17	7	CL-ML



ATTERBERG LIMITS
(ASTM D 4318)

Project Number: 22124-01
Date: Sep-22

Mojave 68, Victorville

Location	Sample No.	Depth (ft)	Molding Moisture Content (%)	Initial Dry Density (pcf)	Final Moisture Content (%)	Expansion Index	Expansion Classification ¹
HS-2	B-1	0-5'	8.0	116.7	15.1	18	Very Low
HS-7	B-1	0-5'	8.1	117.6	12.2	0	Very Low



EXPANSION INDEX
(ASTM D 4829)

Project Number: 22124-01
Date: Sep-22

Mojave 68, Victorville

ONE-DIMENSIONAL CONSOLIDATION PROPERTIES of SOILS

ASTM D 2435

Project Name: Mojave 68, Victorville
 Project No.: 22124-01
 Boring No.: HS-2
 Sample No.: R-2
 Soil Identification: Light olive brown silty sand (SM)

Tested By: GB/JD Date: 09/22/22
 Checked By: J. Ward Date: 10/06/22
 Depth (ft.): 10.0
 Sample Type: Ring

Sample Diameter (in.):	2.415
Sample Thickness (in.):	1.000
Weight of Sample + ring (g):	179.70
Weight of Ring (g):	41.84
Height after consol. (in.):	0.9760
Before Test	
Wt. of Wet Sample+Cont. (g):	179.82
Wt. of Dry Sample+Cont. (g):	176.89
Weight of Container (g):	38.36
Initial Moisture Content (%)	2.1
Initial Dry Density (pcf)	112.3
Initial Saturation (%):	11
Initial Vertical Reading (in.)	0.0981
After Test	
Wt. of Wet Sample+Cont. (g):	252.10
Wt. of Dry Sample+Cont. (g):	231.52
Weight of Container (g):	56.60
Final Moisture Content (%)	15.46
Final Dry Density (pcf):	113.4
Final Saturation (%):	86
Final Vertical Reading (in.)	0.1257
Specific Gravity (assumed):	2.70
Water Density (pcf):	62.43

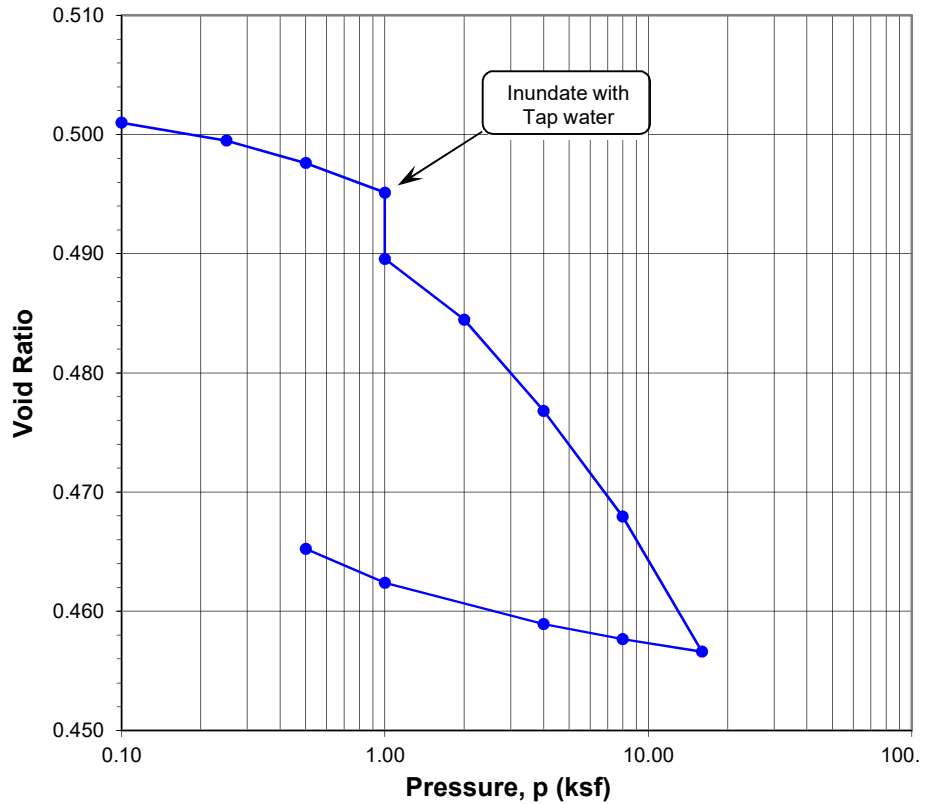

Pressure (p) (ksf)	Final Reading (in.)	Apparent Thickness (in.)	Load Compliance (%)	Deformation % of Sample Thickness	Void Ratio	Corrected Deformation (%)
0.10	0.0983	0.9998	0.00	0.02	0.501	0.02
0.25	0.0998	0.9983	0.05	0.17	0.499	0.12
0.50	0.1017	0.9965	0.11	0.35	0.498	0.24
1.00	0.1041	0.9940	0.19	0.60	0.495	0.41
1.00	0.1078	0.9903	0.19	0.97	0.490	0.78
2.00	0.1122	0.9859	0.29	1.41	0.484	1.12
4.00	0.1186	0.9795	0.42	2.05	0.477	1.63
8.00	0.1258	0.9723	0.55	2.77	0.468	2.22
16.00	0.1348	0.9634	0.69	3.67	0.457	2.98
8.00	0.1334	0.9648	0.62	3.53	0.458	2.91
4.00	0.1318	0.9663	0.55	3.37	0.459	2.82
1.00	0.1281	0.9700	0.41	3.00	0.462	2.59
0.50	0.1257	0.9724	0.36	2.76	0.465	2.40

Time Readings				
Date	Time	Elapsed Time (min)	Square Root of Time	Dial Rdgs. (in.)

Time Readings

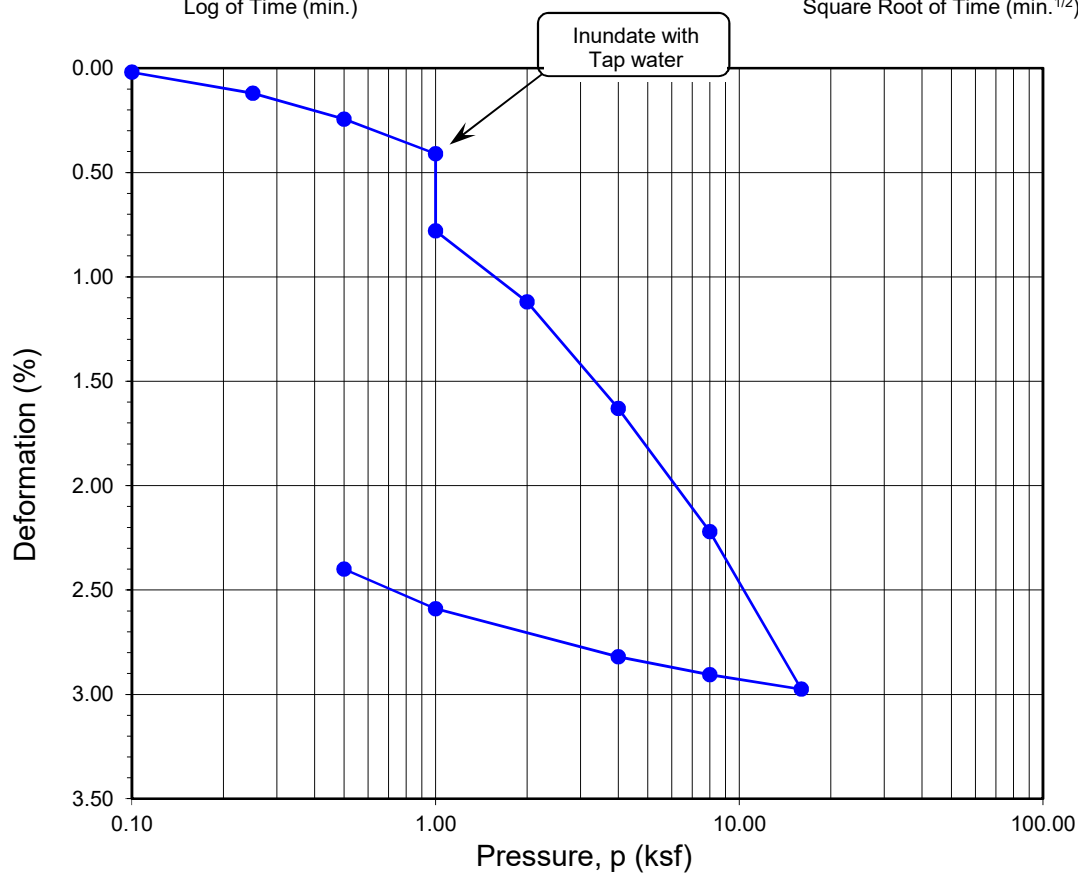
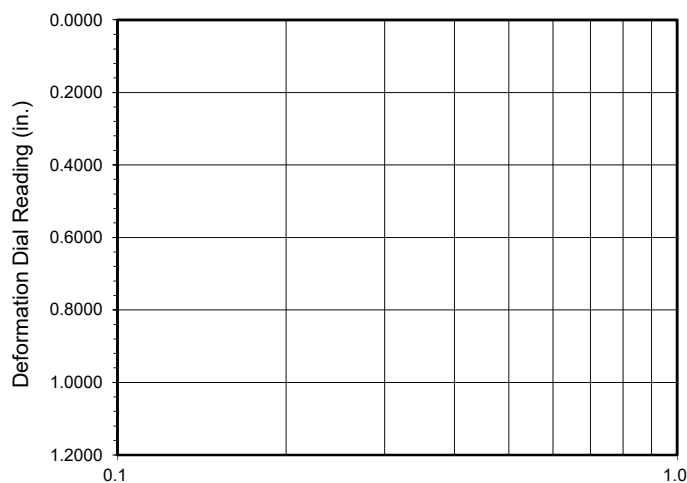

Boring No.	Sample No.	Depth (ft.)	Moisture Content (%)		Dry Density (pcf)		Void Ratio		Degree of Saturation (%)	
			Initial	Final	Initial	Final	Initial	Final	Initial	Final
HS-2	R-2	10	2.1	15.5	112.3	113.4	0.501	0.465	11	86

Soil Identification: Light olive brown silty sand (SM)

**ONE-DIMENSIONAL CONSOLIDATION
PROPERTIES of SOILS
ASTM D 2435**

Project No.: 22124-01

Mojave 68, Victorville

ONE-DIMENSIONAL CONSOLIDATION PROPERTIES of SOILS

ASTM D 2435

Project Name: Mojave 68, Victorville
 Project No.: 22124-01
 Boring No.: HS-4
 Sample No.: R-1
 Soil Identification: Light olive gray silty sand (SM)

Tested By: GB/JD Date: 09/22/22
 Checked By: J. Ward Date: 10/06/22
 Depth (ft.): 5.0
 Sample Type: Ring

Sample Diameter (in.):	2.415
Sample Thickness (in.):	1.000
Weight of Sample + ring (g):	193.08
Weight of Ring (g):	44.56
Height after consol. (in.):	0.9748
Before Test	
Wt. of Wet Sample+Cont. (g):	192.75
Wt. of Dry Sample+Cont. (g):	190.18
Weight of Container (g):	52.65
Initial Moisture Content (%)	1.9
Initial Dry Density (pcf)	121.3
Initial Saturation (%):	13
Initial Vertical Reading (in.)	0.1107
After Test	
Wt. of Wet Sample+Cont. (g):	246.17
Wt. of Dry Sample+Cont. (g):	228.05
Weight of Container (g):	39.00
Final Moisture Content (%)	12.54
Final Dry Density (pcf):	123.3
Final Saturation (%):	92
Final Vertical Reading (in.)	0.1400
Specific Gravity (assumed):	2.70
Water Density (pcf):	62.43

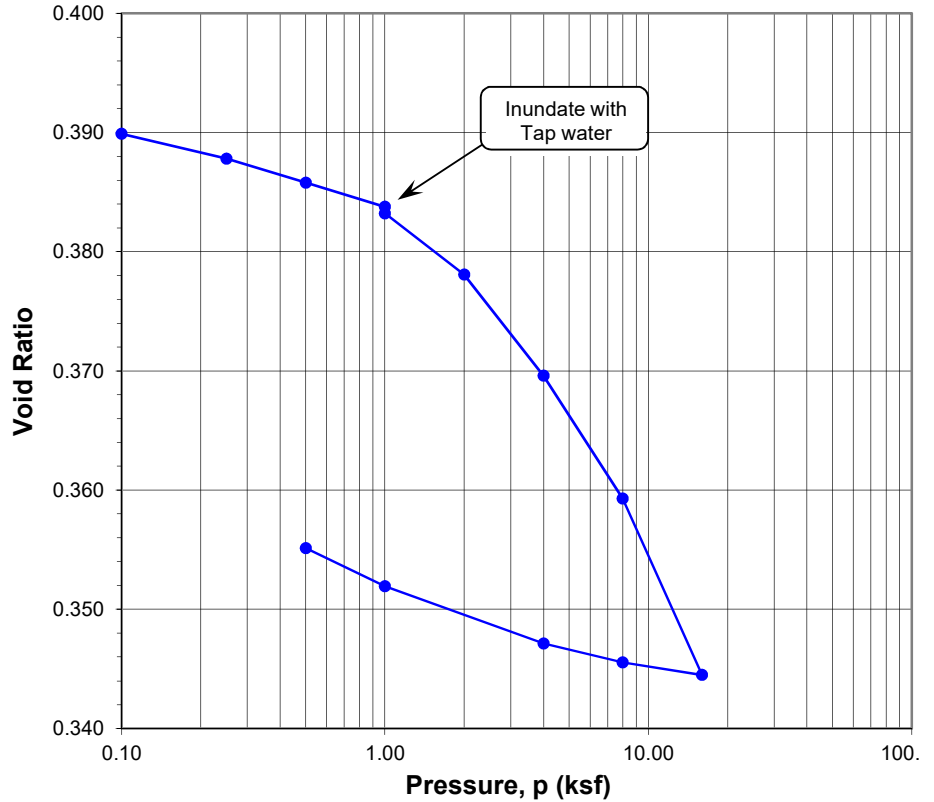

Pressure (p) (ksf)	Final Reading (in.)	Apparent Thickness (in.)	Load Compliance (%)	Deformation % of Sample Thickness	Void Ratio	Corrected Deformation (%)
0.10	0.1109	0.9998	0.00	0.02	0.390	0.02
0.25	0.1129	0.9978	0.05	0.22	0.388	0.17
0.50	0.1151	0.9957	0.12	0.43	0.386	0.31
1.00	0.1176	0.9931	0.23	0.69	0.384	0.46
1.00	0.1180	0.9927	0.23	0.73	0.383	0.50
2.00	0.1229	0.9878	0.35	1.22	0.378	0.87
4.00	0.1304	0.9803	0.49	1.97	0.370	1.48
8.00	0.1392	0.9715	0.63	2.85	0.359	2.22
16.00	0.1514	0.9594	0.78	4.07	0.345	3.29
8.00	0.1498	0.9609	0.70	3.91	0.346	3.21
4.00	0.1479	0.9629	0.62	3.72	0.347	3.10
1.00	0.1429	0.9678	0.47	3.22	0.352	2.75
0.50	0.1400	0.9707	0.41	2.93	0.355	2.52

Time Readings				
Date	Time	Elapsed Time (min)	Square Root of Time	Dial Rdgs. (in.)

Time Readings

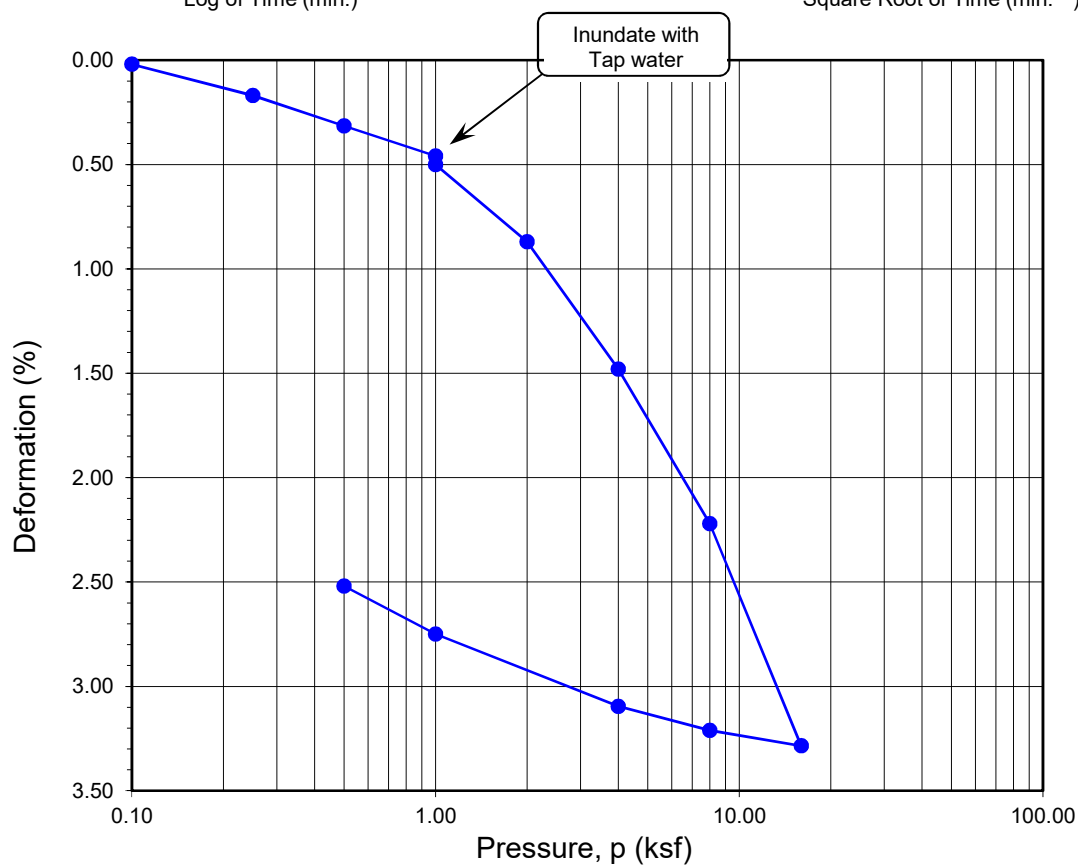
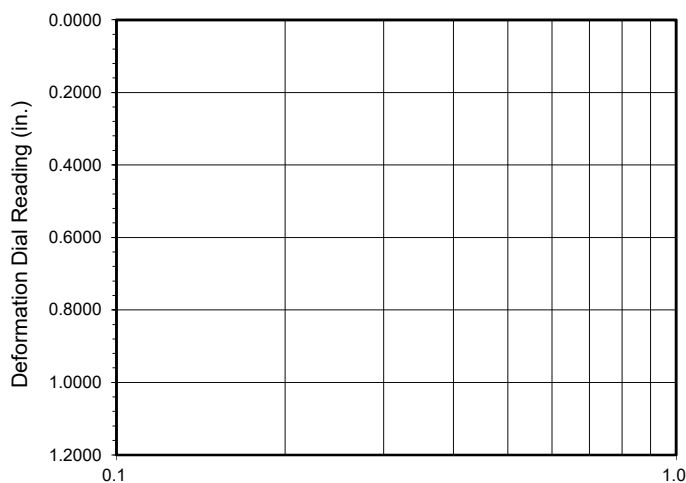

Boring No.	Sample No.	Depth (ft.)	Moisture Content (%)		Dry Density (pcf)		Void Ratio		Degree of Saturation (%)	
			Initial	Final	Initial	Final	Initial	Final	Initial	Final
HS-4	R-1	5	1.9	12.5	121.3	123.3	0.390	0.355	13	92

Soil Identification: Light olive gray silty sand (SM)

**ONE-DIMENSIONAL CONSOLIDATION
PROPERTIES of SOILS
ASTM D 2435**

Project No.: 22124-01

Mojave 68, Victorville

ONE-DIMENSIONAL CONSOLIDATION PROPERTIES of SOILS

ASTM D 2435

Project Name: Mojave 68, Victorville
 Project No.: 22124-01
 Boring No.: HS-9
 Sample No.: R-2
 Soil Identification: Olive gray silty sand (SM)

Tested By: GB/JD Date: 09/22/22
 Checked By: J. Ward Date: 10/06/22
 Depth (ft.): 7.5
 Sample Type: Ring

Sample Diameter (in.):	2.415
Sample Thickness (in.):	1.000
Weight of Sample + ring (g):	185.48
Weight of Ring (g):	45.59
Height after consol. (in.):	0.9761
Before Test	
Wt. of Wet Sample+Cont. (g):	201.77
Wt. of Dry Sample+Cont. (g):	198.00
Weight of Container (g):	58.37
Initial Moisture Content (%)	2.7
Initial Dry Density (pcf)	113.3
Initial Saturation (%)	15
Initial Vertical Reading (in.)	0.1225
After Test	
Wt. of Wet Sample+Cont. (g):	269.05
Wt. of Dry Sample+Cont. (g):	249.11
Weight of Container (g):	66.85
Final Moisture Content (%)	14.59
Final Dry Density (pcf):	116.4
Final Saturation (%):	88
Final Vertical Reading (in.)	0.1504
Specific Gravity (assumed):	2.70
Water Density (pcf):	62.43

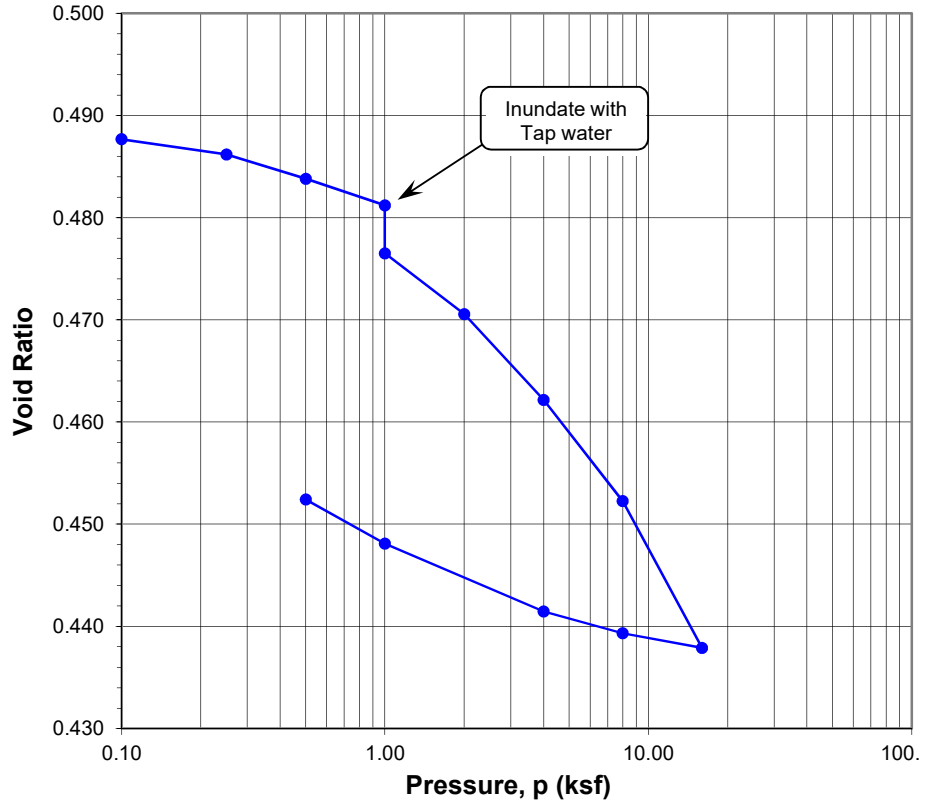

Pressure (p) (ksf)	Final Reading (in.)	Apparent Thickness (in.)	Load Compliance (%)	Deformation % of Sample Thickness	Void Ratio	Corrected Deformation (%)
0.10	0.1227	0.9998	0.00	0.02	0.488	0.02
0.25	0.1242	0.9983	0.05	0.17	0.486	0.12
0.50	0.1266	0.9959	0.13	0.41	0.484	0.28
1.00	0.1293	0.9933	0.22	0.68	0.481	0.46
1.00	0.1324	0.9901	0.22	0.99	0.477	0.77
2.00	0.1376	0.9849	0.34	1.51	0.471	1.17
4.00	0.1447	0.9779	0.48	2.22	0.462	1.74
8.00	0.1529	0.9696	0.64	3.04	0.452	2.40
16.00	0.1648	0.9578	0.86	4.23	0.438	3.37
8.00	0.1624	0.9601	0.72	3.99	0.439	3.27
4.00	0.1599	0.9627	0.61	3.74	0.441	3.13
1.00	0.1539	0.9686	0.46	3.14	0.448	2.68
0.50	0.1504	0.9721	0.40	2.79	0.452	2.39

Time Readings				
Date	Time	Elapsed Time (min)	Square Root of Time	Dial Rdgs. (in.)

Time Readings

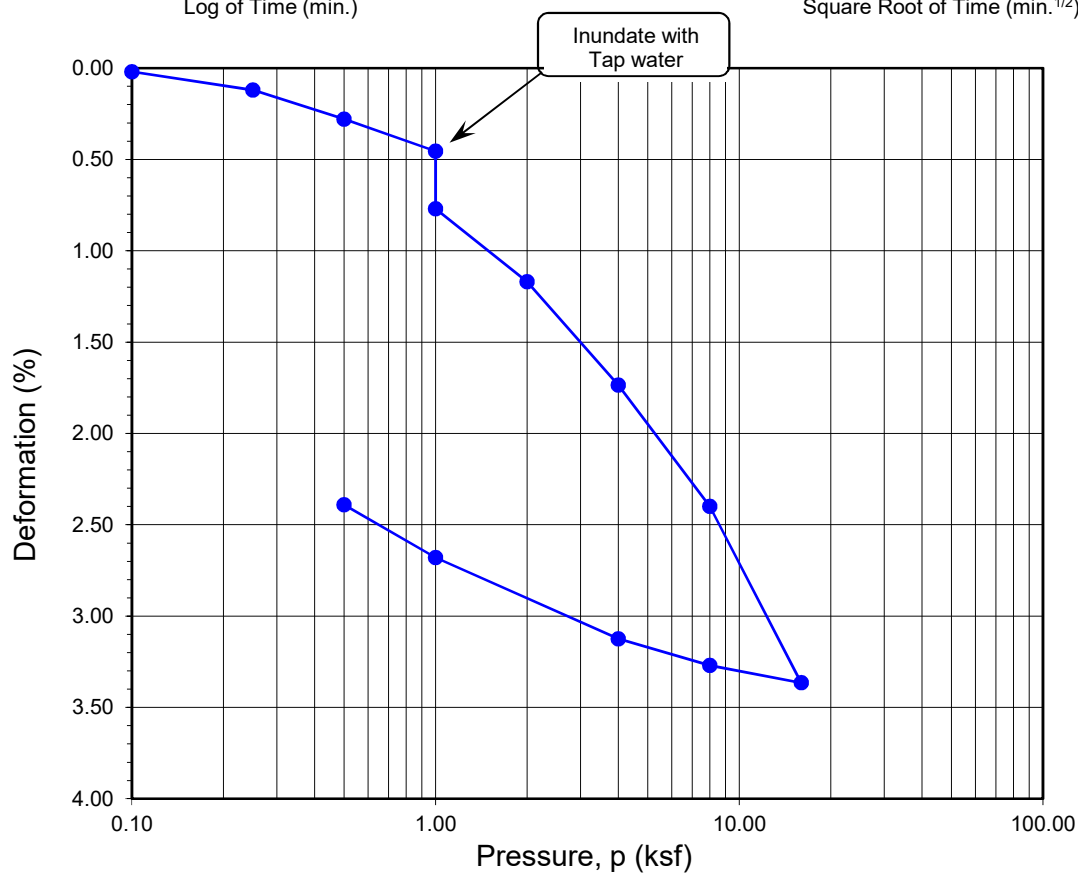
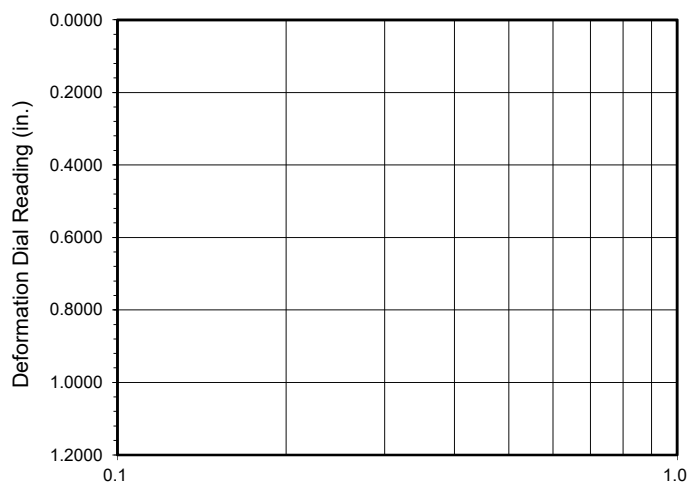

Boring No.	Sample No.	Depth (ft.)	Moisture Content (%)		Dry Density (pcf)		Void Ratio		Degree of Saturation (%)	
			Initial	Final	Initial	Final	Initial	Final	Initial	Final
HS-9	R-2	7.5	2.7	14.6	113.3	116.4	0.488	0.452	15	88

Soil Identification: Olive gray silty sand (SM)

**ONE-DIMENSIONAL CONSOLIDATION
PROPERTIES of SOILS
ASTM D 2435**

Project No.: 22124-01

Mojave 68, Victorville

ONE-DIMENSIONAL CONSOLIDATION PROPERTIES of SOILS

ASTM D 2435

Project Name: Mojave 68, Victorville
 Project No.: 22124-01
 Boring No.: HS-11
 Sample No.: R-3
 Soil Identification: Light brown poorly-graded sand with silt (SP-SM)

Tested By: GB/JD Date: 09/22/22
 Checked By: J. Ward Date: 10/06/22
 Depth (ft.): 15.0
 Sample Type: Ring

Sample Diameter (in.):	2.415
Sample Thickness (in.):	1.000
Weight of Sample + ring (g):	190.17
Weight of Ring (g):	39.01
Height after consol. (in.):	0.9628
Before Test	
Wt. of Wet Sample+Cont. (g):	221.32
Wt. of Dry Sample+Cont. (g):	219.32
Weight of Container (g):	56.14
Initial Moisture Content (%)	1.2
Initial Dry Density (pcf)	124.2
Initial Saturation (%):	9
Initial Vertical Reading (in.)	0.0911
After Test	
Wt. of Wet Sample+Cont. (g):	264.06
Wt. of Dry Sample+Cont. (g):	247.18
Weight of Container (g):	61.73
Final Moisture Content (%)	11.53
Final Dry Density (pcf):	126.5
Final Saturation (%):	94
Final Vertical Reading (in.)	0.1312
Specific Gravity (assumed):	2.70
Water Density (pcf):	62.43

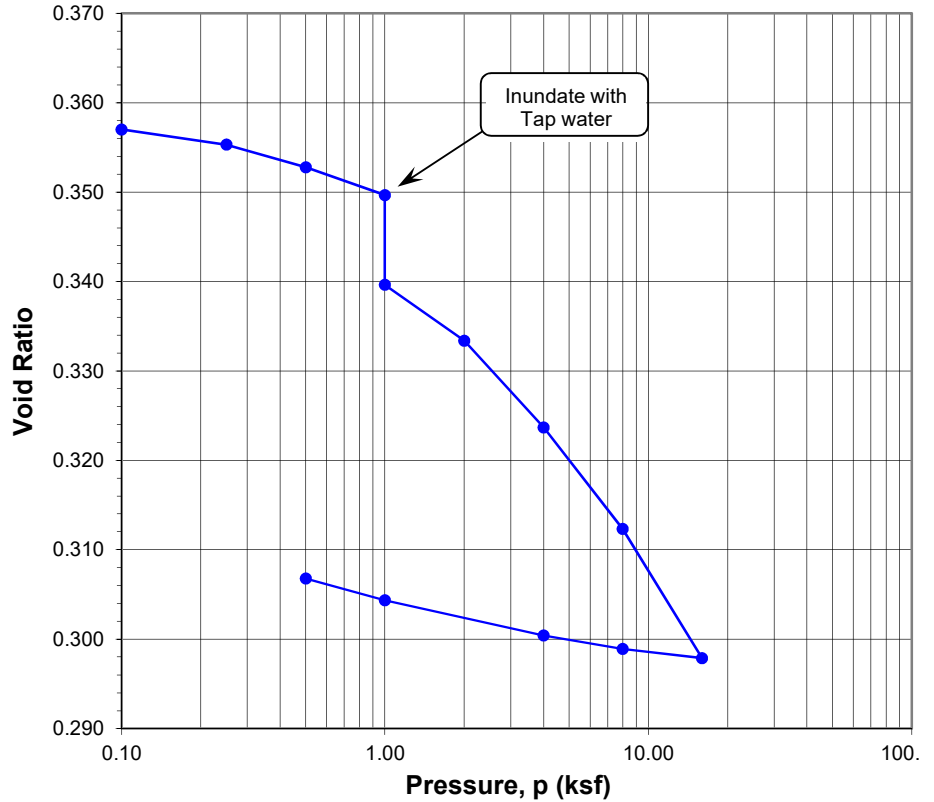

Pressure (p) (ksf)	Final Reading (in.)	Apparent Thickness (in.)	Load Compliance (%)	Deformation % of Sample Thickness	Void Ratio	Corrected Deformation (%)
0.10	0.0913	0.9998	0.00	0.02	0.357	0.02
0.25	0.0929	0.9983	0.03	0.18	0.355	0.15
0.50	0.0952	0.9959	0.08	0.41	0.353	0.33
1.00	0.0982	0.9929	0.15	0.71	0.350	0.56
1.00	0.1056	0.9855	0.15	1.45	0.340	1.30
2.00	0.1112	0.9799	0.25	2.01	0.333	1.76
4.00	0.1195	0.9717	0.36	2.84	0.324	2.48
8.00	0.1291	0.9620	0.49	3.80	0.312	3.31
16.00	0.1413	0.9499	0.64	5.02	0.298	4.38
8.00	0.1396	0.9515	0.55	4.85	0.299	4.30
4.00	0.1377	0.9534	0.47	4.66	0.300	4.19
1.00	0.1335	0.9576	0.34	4.24	0.304	3.90
0.50	0.1312	0.9599	0.29	4.01	0.307	3.72

Time Readings				
Date	Time	Elapsed Time (min)	Square Root of Time	Dial Rdgs. (in.)

Time Readings

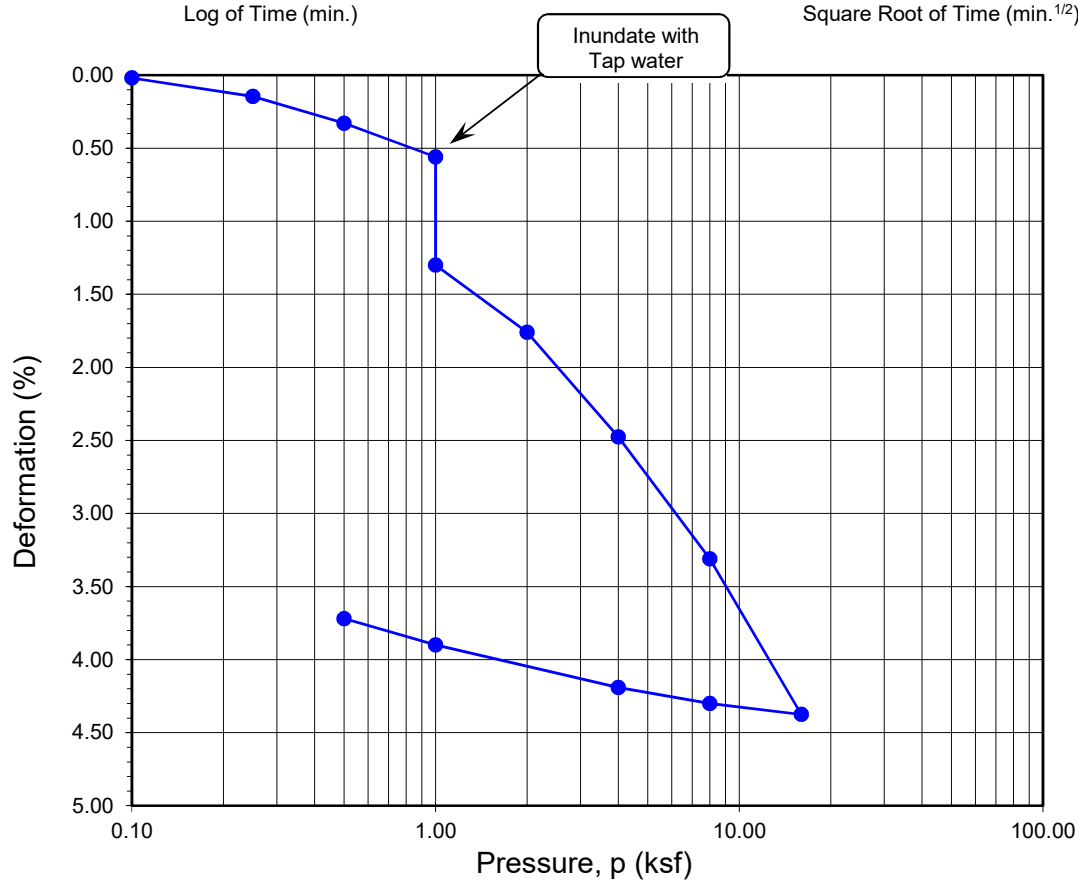
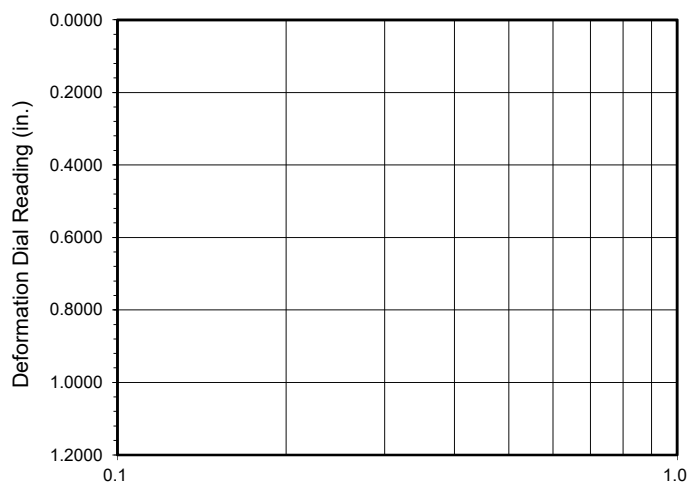

Boring No.	Sample No.	Depth (ft.)	Moisture Content (%)		Dry Density (pcf)		Void Ratio		Degree of Saturation (%)	
			Initial	Final	Initial	Final	Initial	Final	Initial	Final
HS-11	R-3	15	1.2	11.5	124.2	126.5	0.357	0.307	9	94

Soil Identification: Light brown poorly-graded sand with silt (SP-SM)

**ONE-DIMENSIONAL CONSOLIDATION
PROPERTIES of SOILS
ASTM D 2435**

Project No.: 22124-01

Mojave 68, Victorville

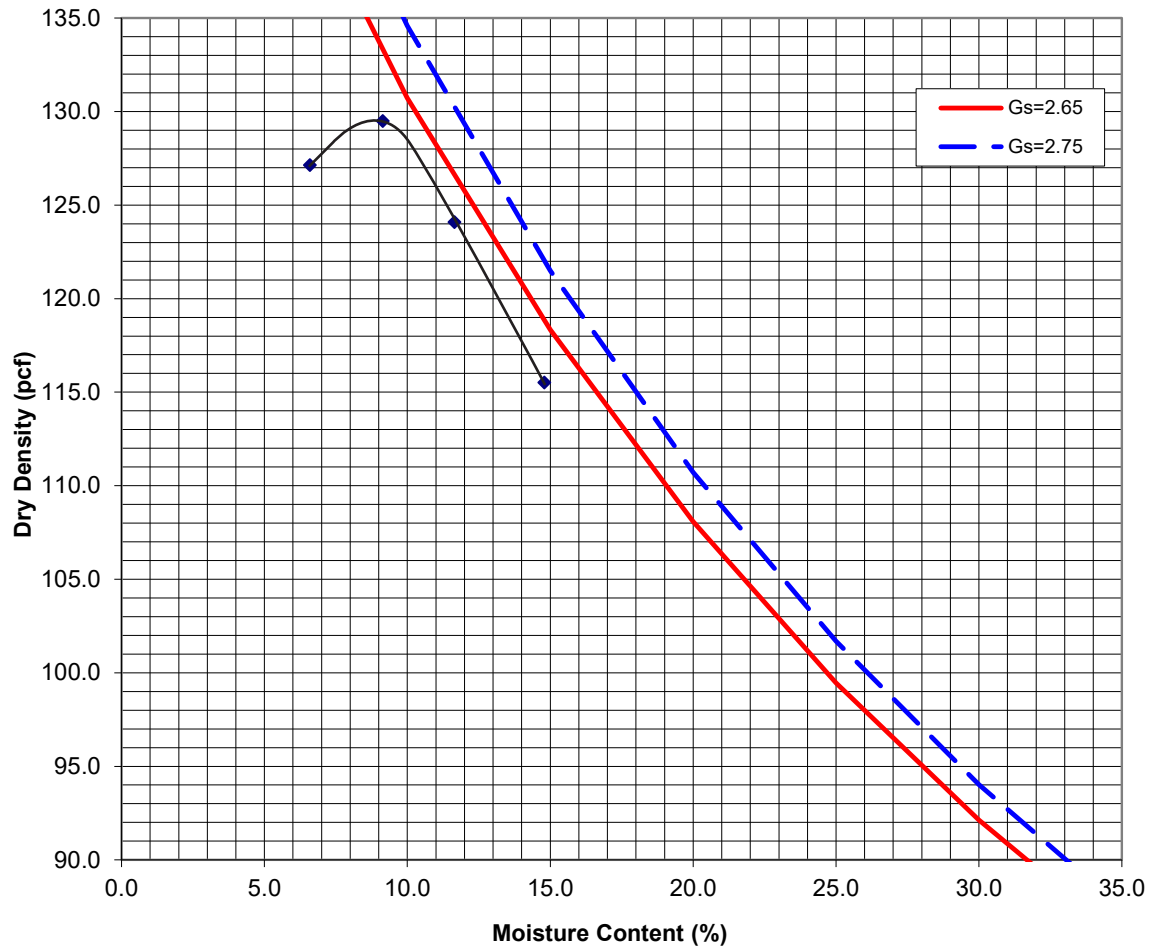

Location:	Sample No.:	Depth (ft)	Sample Description	Maximum Dry Density (pcf)	Optimum Moisture Content (%)
HS-4	B-1	0-5'	Light brown silty SAND (SM)	129.5	9.0



LABORATORY COMPACTION
(ASTM D 1557)

Project Number: 22124-01
Date: Sep-22

Mojave 68, Victorville

R-VALUE TEST RESULTS

DOT CA Test 301

PROJECT NAME:	<u>Mojave 68, Victorville</u>	PROJECT NUMBER:	<u>22124-01</u>
BORING NUMBER:	<u>HS-3</u>	DEPTH (FT.):	<u>0-5</u>
SAMPLE NUMBER:	<u>B-1</u>	TECHNICIAN:	<u>O. Figueroa</u>
SAMPLE DESCRIPTION:	<u>Dark yellowish brown sandy silt (ML)</u>	DATE COMPLETED:	<u>10/1/2022</u>

TEST SPECIMEN	a	b	c
MOISTURE AT COMPACTION %	11.2	12.1	13.1
HEIGHT OF SAMPLE, Inches	2.48	2.54	2.53
DRY DENSITY, pcf	126.8	125.4	122.9
COMPACTOR PRESSURE, psi	130	80	60
EXUDATION PRESSURE, psi	391	263	172
EXPANSION, Inches x 10exp-4	30	11	5
STABILITY Ph 2,000 lbs (160 psi)	74	105	121
TURNS DISPLACEMENT	4.50	4.65	5.10
R-VALUE UNCORRECTED	39	22	14
R-VALUE CORRECTED	39	22	14

DESIGN CALCULATION DATA	a	b	c
GRAVEL EQUIVALENT FACTOR	1.0	1.0	1.0
TRAFFIC INDEX	5.0	5.0	5.0
STABILOMETER THICKNESS, ft.	0.98	1.25	1.38
EXPANSION PRESSURE THICKNESS, ft.	1.00	0.37	0.17

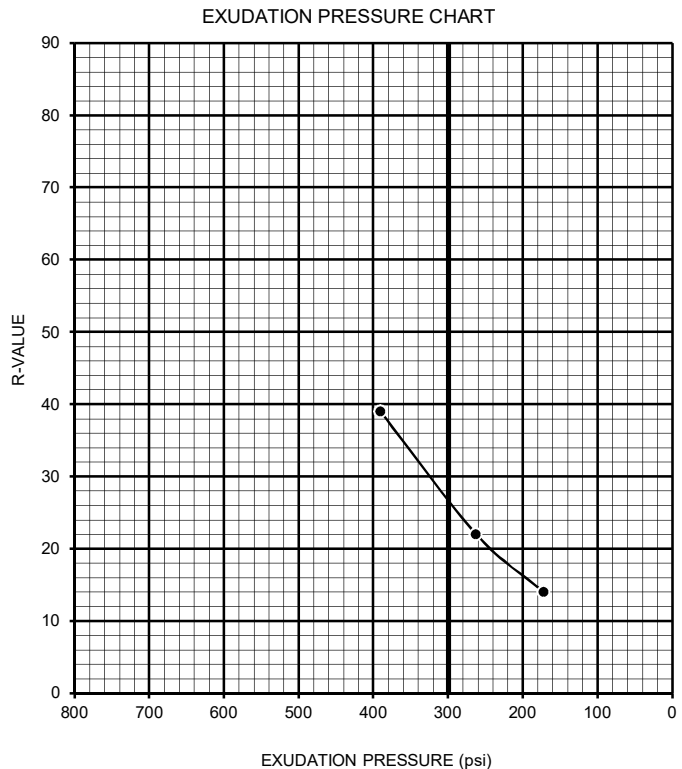
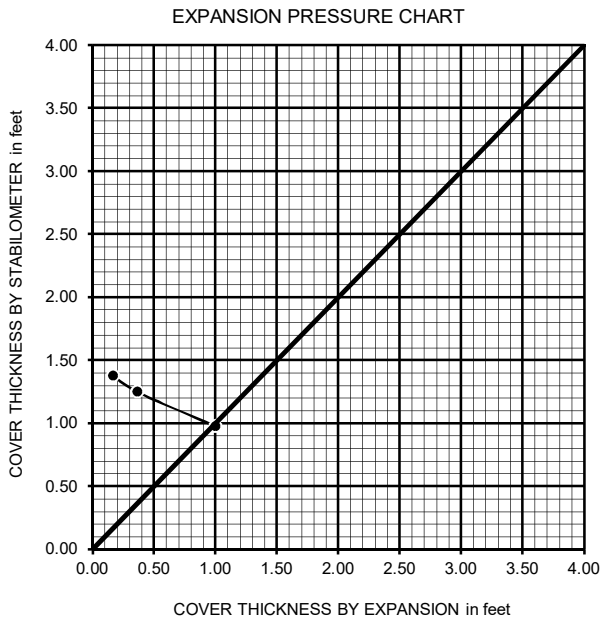

R-VALUE BY EXPANSION:	<u>38</u>
R-VALUE BY EXUDATION:	<u>27</u>
EQUILIBRIUM R-VALUE:	<u>27</u>

**TESTS for SULFATE CONTENT
CHLORIDE CONTENT and pH of SOILS**

Project Name: Mojave 68, Victorville Tested By : GEB/JD Date: 09/21/22
 Project No. : 22124-01 Checked By: J. Ward Date: 10/06/22

Boring No.	HS-2			
Sample No.	B-1			
Sample Depth (ft)	0-5			
Soil Identification:	Yellowish brown SC			
Wet Weight of Soil + Container (g)	210.67			
Dry Weight of Soil + Container (g)	204.81			
Weight of Container (g)	66.76			
Moisture Content (%)	4.24			
Weight of Soaked Soil (g)	100.02			

SULFATE CONTENT, DOT California Test 417, Part II

Beaker No.	2			
Crucible No.	2			
Furnace Temperature (°C)	860			
Time In / Time Out	8:00/8:45			
Duration of Combustion (min)	45			
Wt. of Crucible + Residue (g)	28.7155			
Wt. of Crucible (g)	28.7129			
Wt. of Residue (g) (A)	0.0026			
PPM of Sulfate (A) x 41150	106.99			
PPM of Sulfate, Dry Weight Basis	112			

CHLORIDE CONTENT, DOT California Test 422

ml of Extract For Titration (B)	15			
ml of AgNO ₃ Soln. Used in Titration (C)	0.3			
PPM of Chloride (C -0.2) * 100 * 30 / B	20			
PPM of Chloride, Dry Wt. Basis	21			

pH TEST, DOT California Test 643

pH Value	8.58			
Temperature °C	20.4			

SOIL RESISTIVITY TEST

DOT CA TEST 643

Project Name: Mojave 68, Victorville
 Project No. : 22124-01
 Boring No.: HS-2
 Sample No. : B-1

Tested By : J. Domingo Date: 10/03/22
 Checked By: J. Ward Date: 10/06/22
 Depth (ft.) : 0-5

Soil Identification:* Yellowish brown SC

*California Test 643 requires soil specimens to consist only of portions of samples passing through the No. 8 US Standard Sieve before resistivity testing. Therefore, this test method may not be representative for coarser materials.

Specimen No.	Water Added (ml) (Wa)	Adjusted Moisture Content (MC)	Resistance Reading (ohm)	Soil Resistivity (ohm-cm)
1	10	12.24	3000	3000
2	20	20.23	2600	2600
3	30	28.23	2700	2700
4				
5				

Moisture Content (%) (Mci)	4.24
Wet Wt. of Soil + Cont. (g)	210.67
Dry Wt. of Soil + Cont. (g)	204.81
Wt. of Container (g)	66.76
Container No.	
Initial Soil Wt. (g) (Wt)	130.40
Box Constant	1.000
$MC = (((1 + Mci / 100) \times (Wa / Wt + 1)) - 1) \times 100$	

Min. Resistivity (ohm-cm)	Moisture Content (%)	Sulfate Content (ppm)	Chloride Content (ppm)	Soil pH	
				pH	Temp. (°C)
DOT CA Test 643		DOT CA Test 417 Part II		DOT CA Test 643	
2590	21.6	112	21	8.58	20.4

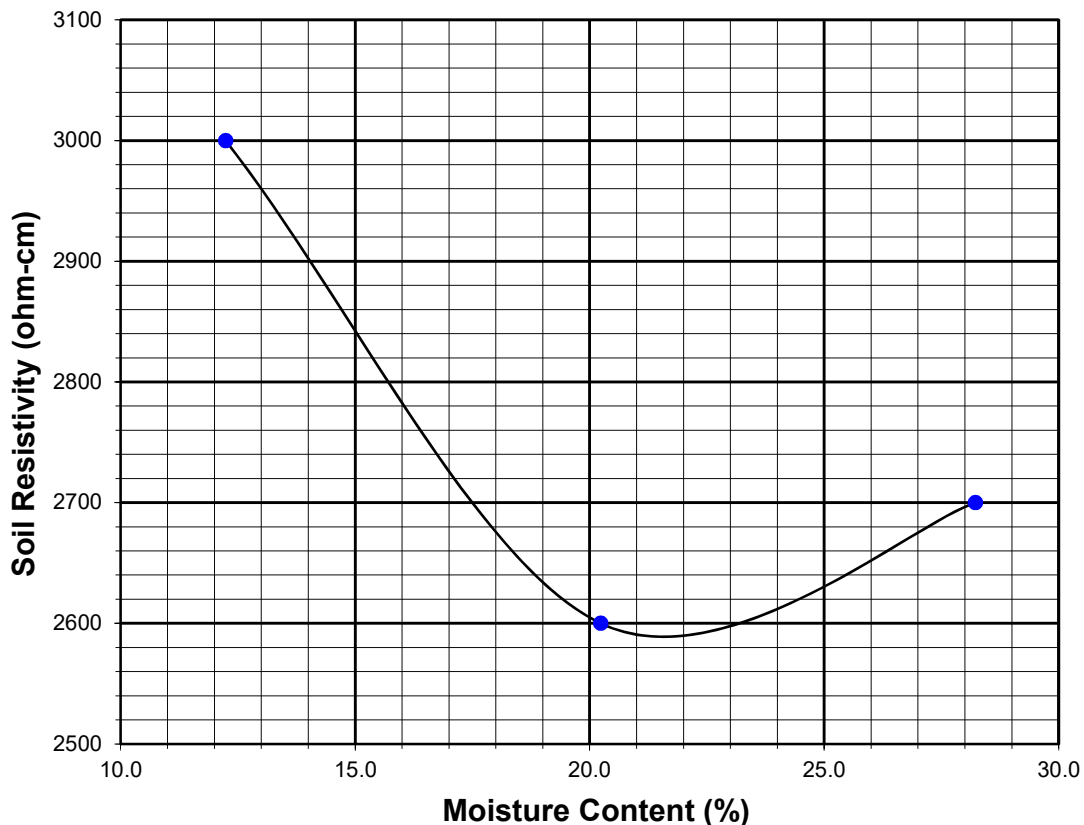

**TESTS for SULFATE CONTENT
CHLORIDE CONTENT and pH of SOILS**

Project Name: Mojave 68, Victorville Tested By : GEB/JD Date: 09/21/22
 Project No. : 22124-01 Checked By: J. Ward Date: 10/06/22

Boring No.	HS-7			
Sample No.	B-1			
Sample Depth (ft)	0-5			
Soil Identification:	Yellowish brown SC			
Wet Weight of Soil + Container (g)	162.95			
Dry Weight of Soil + Container (g)	159.00			
Weight of Container (g)	58.55			
Moisture Content (%)	3.93			
Weight of Soaked Soil (g)	100.03			

SULFATE CONTENT, DOT California Test 417, Part II

Beaker No.	9			
Crucible No.	8			
Furnace Temperature (°C)	860			
Time In / Time Out	8:00/8:45			
Duration of Combustion (min)	45			
Wt. of Crucible + Residue (g)	20.4031			
Wt. of Crucible (g)	20.4001			
Wt. of Residue (g) (A)	0.0030			
PPM of Sulfate (A) x 41150	123.45			
PPM of Sulfate, Dry Weight Basis	129			

CHLORIDE CONTENT, DOT California Test 422

ml of Extract For Titration (B)				
ml of AgNO ₃ Soln. Used in Titration (C)				
PPM of Chloride (C -0.2) * 100 * 30 / B				
PPM of Chloride, Dry Wt. Basis	N/A			

pH TEST, DOT California Test 643

pH Value	N/A			
Temperature °C				

Appendix D
Infiltration Testing

Infiltration Test Data Sheet

LGC Geotechnical, Inc

131 Calle Iglesia Suite 200, San Clemente, CA 92672 tel. (949) 369-6141

Project Name: Mojave 68 - Victoville
Project Number: 22124-01
Date: 9/14/2022
Boring Number: I-1

Test hole dimensions (if circular)	
Boring Depth (feet)*:	10.19
Boring Diameter (inches):	8
Pipe Diameter (inches):	3

*measured at time of test

Test pit dimensions (if rectangular)	
Pit Depth (feet):	
Pit Length (feet):	
Pit Breadth (feet):	

Pre-Test (Sandy Soil Criteria)*

Trial No.	Start Time (24:HR)	Stop Time (24:HR)	Time Interval (min)	Initial Depth to Water (feet)	Final Depth to Water (feet)	Total Change in Water Level (feet)	Greater Than or Equal to 0.5 feet (yes/no)
1	8:41	9:06	25.0	8.09	9.72	1.63	Yes
2	9:09	9:34	25.0	7.85	9.65	1.80	Yes

*If two consecutive measurements show that six inches of water seeps away in less than 25 minutes, the test shall be run for an additional hour with measurements taken every 10 minutes. Otherwise, pre-soak (fill) overnight, and then obtain at least twelve measurements per hole over at least six hours (approximately 30 minute intervals) with a precision of at least 0.25 inches

Main Test Data

Trial No.	Start Time (24:HR)	Stop Time (24:HR)	Time Interval, Δt (min)	Initial Depth to Water, D _o (feet)	Final Depth to Water, D _f (feet)	Change in Water Level, ΔD (feet)	Observed Infiltration Rate(in/hr)
1	9:40	9:50	10.0	7.75	8.80	1.05	6.1
2	9:52	10:02	10.0	7.82	8.92	1.10	6.6
3	10:03	10:13	10.0	7.94	8.93	0.99	6.2
4	10:14	10:24	10.0	7.93	8.94	1.01	6.3
5	10:26	10:36	10.0	8.03	9.05	1.02	6.7
6	10:39	10:49	10.0	8.01	9.06	1.05	6.9

Observed Infiltration Rate (Does Not Include Any Factor of Safety) 6.9

Sketch:

Notes:



Infiltration Test Data Sheet

LGC Geotechnical, Inc

131 Calle Iglesia Suite 200, San Clemente, CA 92672 tel. (949) 369-6141

Project Name: Mojave 68 - Victoville
Project Number: 22124-01
Date: 9/14/2022
Boring Number: I-2

Test hole dimensions (if circular)

Boring Depth (feet)*: 10.22
 Boring Diameter (inches): 8
 Pipe Diameter (inches): 3

*measured at time of test

Test pit dimensions (if rectangular)

Pit Depth (feet): _____
 Pit Length (feet): _____
 Pit Breadth (feet): _____

Pre-Test (Sandy Soil Criteria)*

Trial No.	Start Time (24:HR)	Stop Time (24:HR)	Time Interval (min)	Initial Depth to Water (feet)	Final Depth to Water (feet)	Total Change in Water Level (feet)	Greater Than or Equal to 0.5 feet (yes/no)
1	8:52	9:17	25.0	7.90	9.35	1.45	Yes
2	9:19	9:44	25.0	8.05	9.36	1.31	Yes

*If two consecutive measurements show that six inches of water seeps away in less than 25 minutes, the test shall be run for an additional hour with measurements taken every 10 minutes. Otherwise, pre-soak (fill) overnight, and then obtain at least twelve measurements per hole over at least six hours (approximately 30 minute intervals) with a precision of at least 0.25 inches

Main Test Data

Trial No.	Start Time (24:HR)	Stop Time (24:HR)	Time Interval, Δt (min)	Initial Depth to Water, D_o (feet)	Final Depth to Water, D_f (feet)	Change in Water Level, ΔD (feet)	Observed Infiltration Rate(in/hr)
1	9:45	9:55	10.0	7.95	8.67	0.72	4.2
2	9:56	10:06	10.0	7.92	8.65	0.73	4.2
3	10:09	10:19	10.0	7.96	8.72	0.76	4.5
4	10:21	10:31	10.0	8.00	8.74	0.74	4.4
5	10:34	10:44	10.0	7.95	8.74	0.79	4.6
6	10:46	10:56	10.0	8.00	8.75	0.75	4.5

Observed Infiltration Rate (Does Not Include Any Factor of Safety) 4.5

Sketch:

Notes:



Appendix E
General Earthwork and Grading Specifications

General Earthwork and Grading Specifications for Rough Grading

1.0 General

1.1 Intent

These General Earthwork and Grading Specifications are for the grading and earthwork shown on the approved grading plan(s) and/or indicated in the geotechnical report(s). These Specifications are a part of the recommendations contained in the geotechnical report(s). In case of conflict, the specific recommendations in the geotechnical report shall supersede these more general Specifications. Observations of the earthwork by the project Geotechnical Consultant during the course of grading may result in new or revised recommendations that could supersede these specifications or the recommendations in the geotechnical report(s).

1.2 The Geotechnical Consultant of Record

Prior to commencement of work, the owner shall employ a qualified Geotechnical Consultant of Record (Geotechnical Consultant). The Geotechnical Consultant shall be responsible for reviewing the approved geotechnical report(s) and accepting the adequacy of the preliminary geotechnical findings, conclusions, and recommendations prior to the commencement of the grading.

Prior to commencement of grading, the Geotechnical Consultant shall review the "work plan" prepared by the Earthwork Contractor (Contractor) and schedule sufficient personnel to perform the appropriate level of observation, mapping, and compaction testing.

During the grading and earthwork operations, the Geotechnical Consultant shall observe, map, and document the subsurface exposures to verify the geotechnical design assumptions. If the observed conditions are found to be significantly different than the interpreted assumptions during the design phase, the Geotechnical Consultant shall inform the owner, recommend appropriate changes in design to accommodate the observed conditions, and notify the review agency where required.

The Geotechnical Consultant shall observe the moisture-conditioning and processing of the subgrade and fill materials and perform relative compaction testing of fill to confirm that the attained level of compaction is being accomplished as specified. The Geotechnical Consultant shall provide the test results to the owner and the Contractor on a routine and frequent basis.

1.3 The Earthwork Contractor

The Earthwork Contractor (Contractor) shall be qualified, experienced, and knowledgeable in earthwork logistics, preparation and processing of ground to receive fill, moisture-conditioning and processing of fill, and compacting fill. The Contractor shall review and accept the plans, geotechnical report(s), and these Specifications prior to commencement of grading. The Contractor shall be solely responsible for performing the grading in accordance with the project plans and specifications. The Contractor shall prepare and submit to the owner and the Geotechnical Consultant a work plan that indicates the sequence of earthwork grading, the number of "equipment" of work and the estimated quantities of daily earthwork

contemplated for the site prior to commencement of grading. The Contractor shall inform the owner and the Geotechnical Consultant of changes in work schedules and updates to the work plan at least 24 hours in advance of such changes so that appropriate personnel will be available for observation and testing. The Contractor shall not assume that the Geotechnical Consultant is aware of all grading operations.

The Contractor shall have the sole responsibility to provide adequate equipment and methods to accomplish the earthwork in accordance with the applicable grading codes and agency ordinances, these Specifications, and the recommendations in the approved geotechnical report(s) and grading plan(s). If, in the opinion of the Geotechnical Consultant, unsatisfactory conditions, such as unsuitable soil, improper moisture condition, inadequate compaction, insufficient buttress key size, adverse weather, etc., are resulting in a quality of work less than required in these specifications, the Geotechnical Consultant shall reject the work and may recommend to the owner that construction be stopped until the conditions are rectified. It is the contractor's sole responsibility to provide proper fill compaction.

2.0 Preparation of Areas to be Filled

2.1 Clearing and Grubbing

Vegetation, such as brush, grass, roots, and other deleterious material shall be sufficiently removed and properly disposed of in a method acceptable to the owner, governing agencies, and the Geotechnical Consultant.

The Geotechnical Consultant shall evaluate the extent of these removals depending on specific site conditions. Earth fill material shall not contain more than 1 percent of organic materials (by volume). Nesting of the organic materials shall not be allowed.

If potentially hazardous materials are encountered, the Contractor shall stop work in the affected area, and a hazardous material specialist shall be informed immediately for proper evaluation and handling of these materials prior to continuing to work in that area.

As presently defined by the State of California, most refined petroleum products (gasoline, diesel fuel, motor oil, grease, coolant, etc.) have chemical constituents that are considered to be hazardous waste. As such, the indiscriminate dumping or spillage of these fluids onto the ground may constitute a misdemeanor, punishable by fines and/or imprisonment, and shall not be allowed. The contractor is responsible for all hazardous waste relating to his work. The Geotechnical Consultant does not have expertise in this area. If hazardous waste is a concern, then the Client should acquire the services of a qualified environmental assessor.

2.2 Processing

Existing ground that has been declared satisfactory for support of fill by the Geotechnical Consultant shall be scarified to a minimum depth of 6 inches. Existing ground that is not satisfactory shall be over-excavated as specified in the following section. Scarification shall continue until soils are broken down and free of oversize material and the working surface is reasonably uniform, flat, and free of uneven features that would inhibit uniform compaction.

2.3 Over-excavation

In addition to removals and over-excavations recommended in the approved geotechnical report(s) and the grading plan, soft, loose, dry, saturated, spongy, organic-rich, highly fractured or otherwise unsuitable ground shall be over-excavated to competent ground as evaluated by the Geotechnical Consultant during grading.

2.4 Benching

Where fills are to be placed on ground with slopes steeper than 5:1 (horizontal to vertical units), the ground shall be stepped or benched. Please see the Standard Details for a graphic illustration. The lowest bench or key shall be a minimum of 15 feet wide and at least 2 feet deep, into competent material as evaluated by the Geotechnical Consultant. Other benches shall be excavated a minimum height of 4 feet into competent material or as otherwise recommended by the Geotechnical Consultant. Fill placed on ground sloping flatter than 5:1 shall also be benched or otherwise over-excavated to provide a flat subgrade for the fill.

2.5 Evaluation/Acceptance of Fill Areas

All areas to receive fill, including removal and processed areas, key bottoms, and benches, shall be observed, mapped, elevations recorded, and/or tested prior to being accepted by the Geotechnical Consultant as suitable to receive fill. The Contractor shall obtain a written acceptance from the Geotechnical Consultant prior to fill placement. A licensed surveyor shall provide the survey control for determining elevations of processed areas, keys, and benches.

3.0 Fill Material

3.1 General

Material to be used as fill shall be essentially free of organic matter and other deleterious substances evaluated and accepted by the Geotechnical Consultant prior to placement. Soils of poor quality, such as those with unacceptable gradation, high expansion potential, or low strength shall be placed in areas acceptable to the Geotechnical Consultant or mixed with other soils to achieve satisfactory fill material.

3.2 Oversize

Oversize material defined as rock, or other irreducible material with a maximum dimension greater than 8 inches, shall not be buried or placed in fill unless location, materials, and placement methods are specifically accepted by the Geotechnical Consultant. Placement operations shall be such that nesting of oversized material does not occur and such that oversize material is completely surrounded by compacted or densified fill. Oversize material shall not be placed within 10 vertical feet of finish grade or within 2 feet of future utilities or underground construction.

3.3 Import

If importing of fill material is required for grading, proposed import material shall meet the requirements of the geotechnical consultant. The potential import source shall be given to the Geotechnical Consultant at least 48 hours (2 working days) before importing begins so that its suitability can be determined and appropriate tests performed.

4.0 Fill Placement and Compaction

4.1 Fill Layers

Approved fill material shall be placed in areas prepared to receive fill (per Section 3.0) in near-horizontal layers not exceeding 8 inches in loose thickness. The Geotechnical Consultant may accept thicker layers if testing indicates the grading procedures can adequately compact the thicker layers. Each layer shall be spread evenly and mixed thoroughly to attain relative uniformity of material and moisture throughout.

4.2 Fill Moisture Conditioning

Fill soils shall be watered, dried back, blended, and/or mixed, as necessary to attain a relatively uniform moisture content at or slightly over optimum. Maximum density and optimum soil moisture content tests shall be performed in accordance with the American Society of Testing and Materials (ASTM Test Method D1557).

4.3 Compaction of Fill

After each layer has been moisture-conditioned, mixed, and evenly spread, it shall be uniformly compacted to not less than 90 percent of maximum dry density (ASTM Test Method D1557). Compaction equipment shall be adequately sized and be either specifically designed for soil compaction or of proven reliability to efficiently achieve the specified level of compaction with uniformity.

4.4 Compaction of Fill Slopes

In addition to normal compaction procedures specified above, compaction of slopes shall be accomplished by backrolling of slopes with sheepsfoot rollers at increments of 3 to 4 feet in fill elevation, or by other methods producing satisfactory results acceptable to the Geotechnical Consultant. Upon completion of grading, relative compaction of the fill, out to the slope face, shall be at least 90 percent of maximum density per ASTM Test Method D1557.

4.5 Compaction Testing

Field tests for moisture content and relative compaction of the fill soils shall be performed by the Geotechnical Consultant. Location and frequency of tests shall be at the Consultant's discretion based on field conditions encountered. Compaction test locations will not necessarily be selected on a random basis. Test locations shall be selected to verify adequacy of compaction levels in areas that are judged to be prone to inadequate compaction (such as close to slope faces and at the fill/bedrock benches).

4.6 Frequency of Compaction Testing

Tests shall be taken at intervals not exceeding 2 feet in vertical rise and/or 1,000 cubic yards of compacted fill soils embankment. In addition, as a guideline, at least one test shall be taken on slope faces for each 5,000 square feet of slope face and/or each 10 feet of vertical height of slope. The Contractor shall assure that fill construction is such that the testing schedule can be accomplished by the Geotechnical Consultant. The Contractor shall stop or slow down the earthwork construction if these minimum standards are not met.

4.7 Compaction Test Locations

The Geotechnical Consultant shall document the approximate elevation and horizontal coordinates of each test location. The Contractor shall coordinate with the project surveyor to assure that sufficient grade stakes are established so that the Geotechnical Consultant can determine the test locations with sufficient accuracy. At a minimum, two grade stakes within a horizontal distance of 100 feet and vertically less than 5 feet apart from potential test locations shall be provided.

5.0 Subdrain Installation

Subdrain systems shall be installed in accordance with the approved geotechnical report(s), the grading plan, and the Standard Details. The Geotechnical Consultant may recommend additional subdrains and/or changes in subdrain extent, location, grade, or material depending on conditions encountered during grading. All subdrains shall be surveyed by a land surveyor/civil engineer for line and grade after installation and prior to burial. Sufficient time should be allowed by the Contractor for these surveys.

6.0 Excavation

Excavations, as well as over-excavation for remedial purposes, shall be evaluated by the Geotechnical Consultant during grading. Remedial removal depths shown on geotechnical plans are estimates only. The actual extent of removal shall be determined by the Geotechnical Consultant based on the field evaluation of exposed conditions during grading. Where fill-over-cut slopes are to be graded, the cut portion of the slope shall be made, evaluated, and accepted by the Geotechnical Consultant prior to placement of materials for construction of the fill portion of the slope, unless otherwise recommended by the Geotechnical Consultant.

7.0 Trench Backfills

7.1 The Contractor shall follow all OSHA and Cal/OSHA requirements for safety of trench excavations.

7.2 All bedding and backfill of utility trenches shall be done in accordance with the applicable provisions of Standard Specifications of Public Works Construction. Bedding material shall have a Sand Equivalent greater than 30 (SE>30). The bedding shall be placed to 1 foot over

the top of the conduit and densified by jetting. Backfill shall be placed and densified to a minimum of 90 percent of maximum from 1 foot above the top of the conduit to the surface.

- 7.3 The jetting of the bedding around the conduits shall be observed by the Geotechnical Consultant.
- 7.4 The Geotechnical Consultant shall test the trench backfill for relative compaction. At least one test should be made for every 300 feet of trench and 2 feet of fill.
- 7.5 Lift thickness of trench backfill shall not exceed those allowed in the Standard Specifications of Public Works Construction unless the Contractor can demonstrate to the Geotechnical Consultant that the fill lift can be compacted to the minimum relative compaction by his alternative equipment and method.

Fill Slope

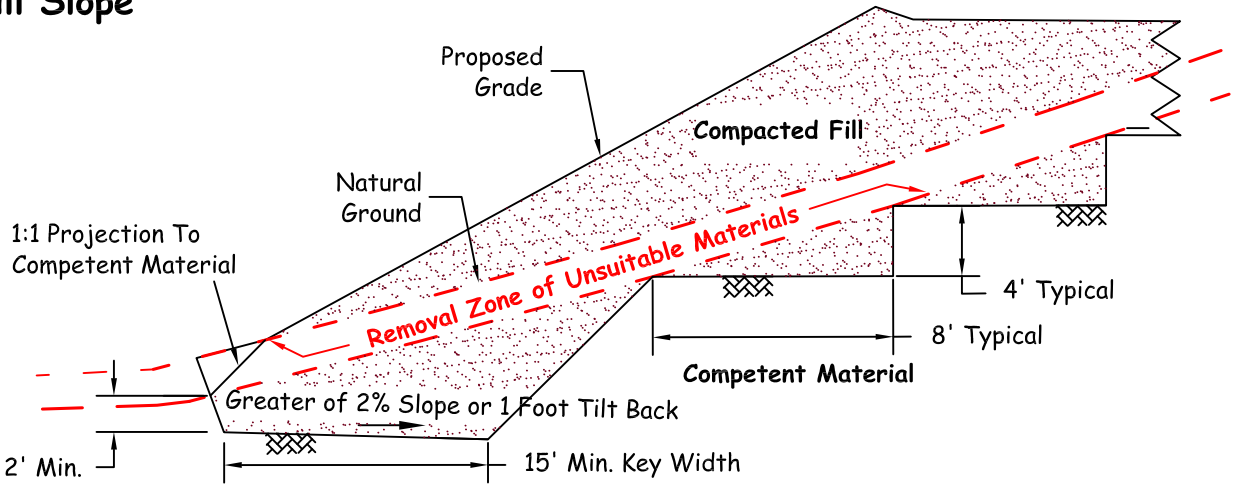

Fill-Over-Cut Slope

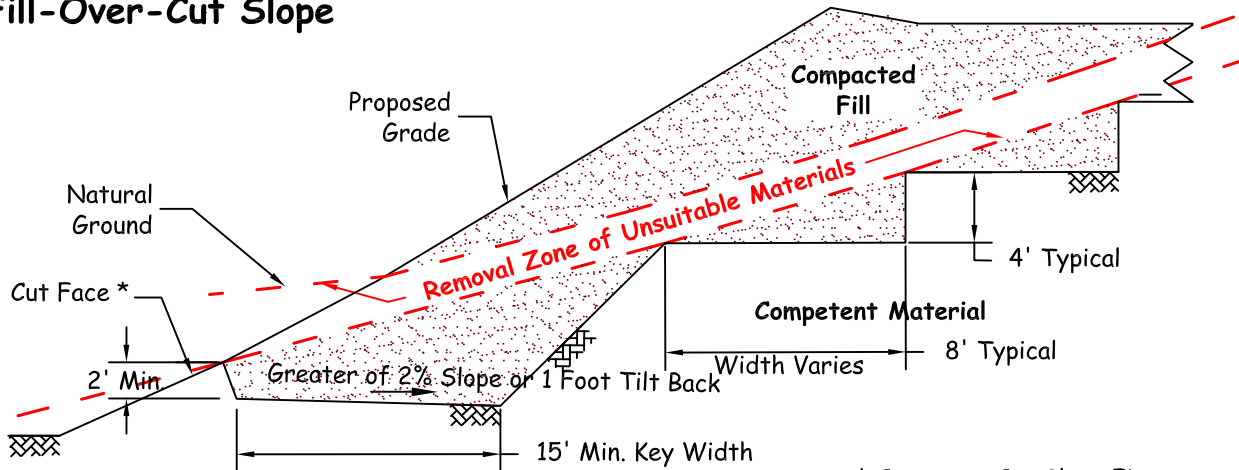

* Construct Cut Slope First

Cut-Over-Fill Slope

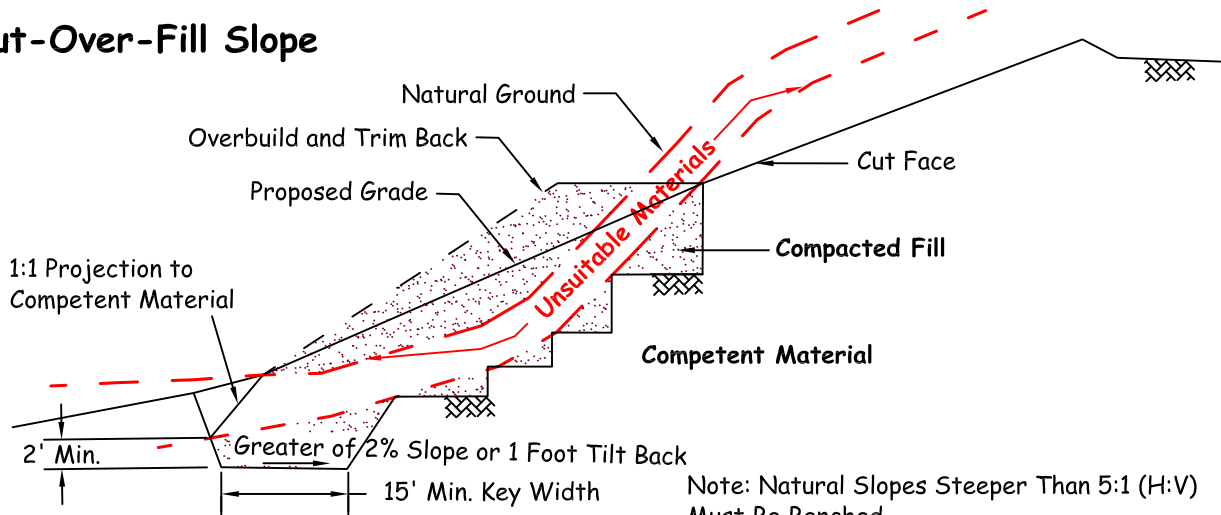

Note: Natural Slopes Steeper Than 5:1 (H:V) Must Be Benched.



KEYING AND BENCHING

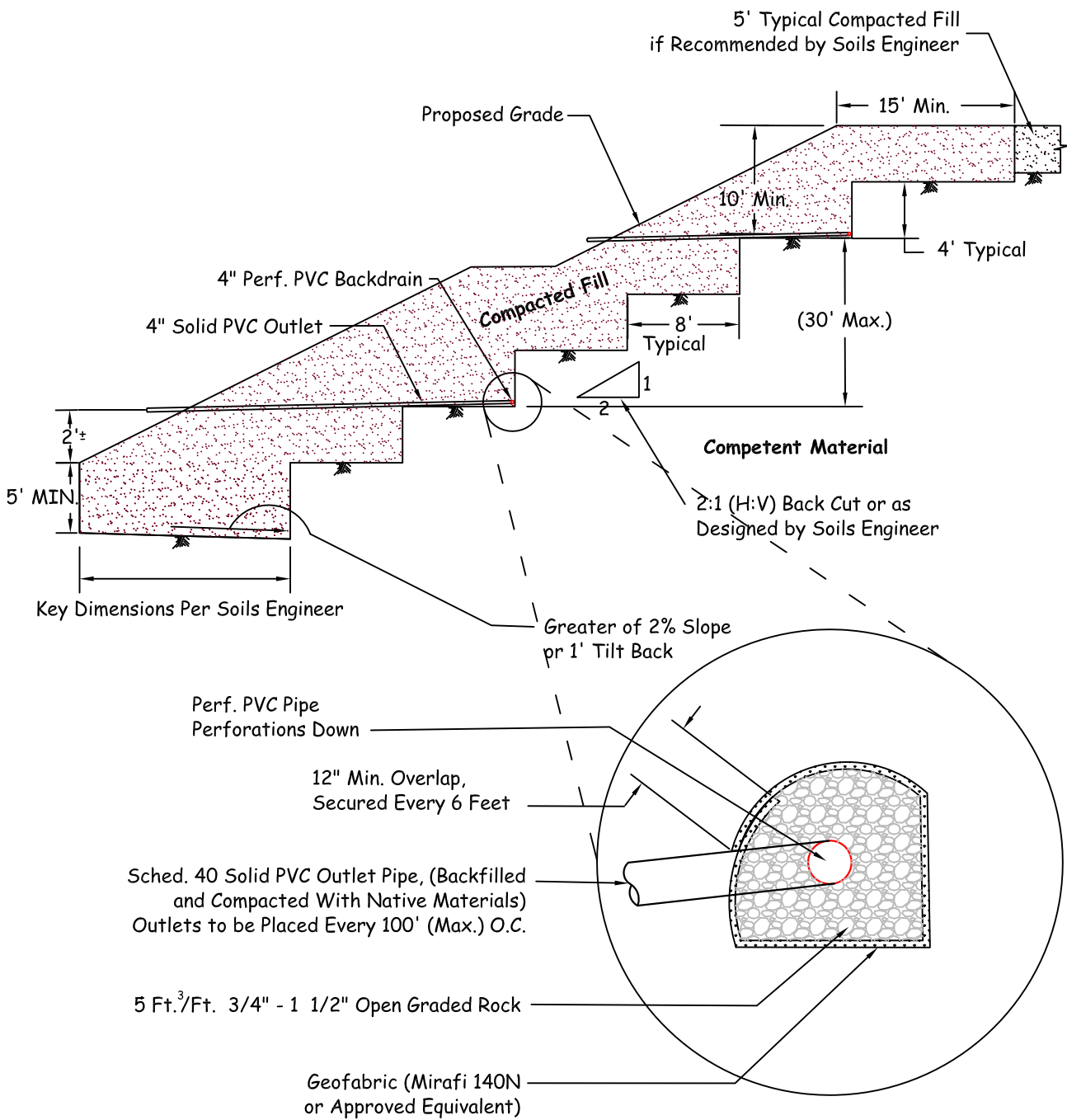

TYPICAL BUTTRESS DETAIL

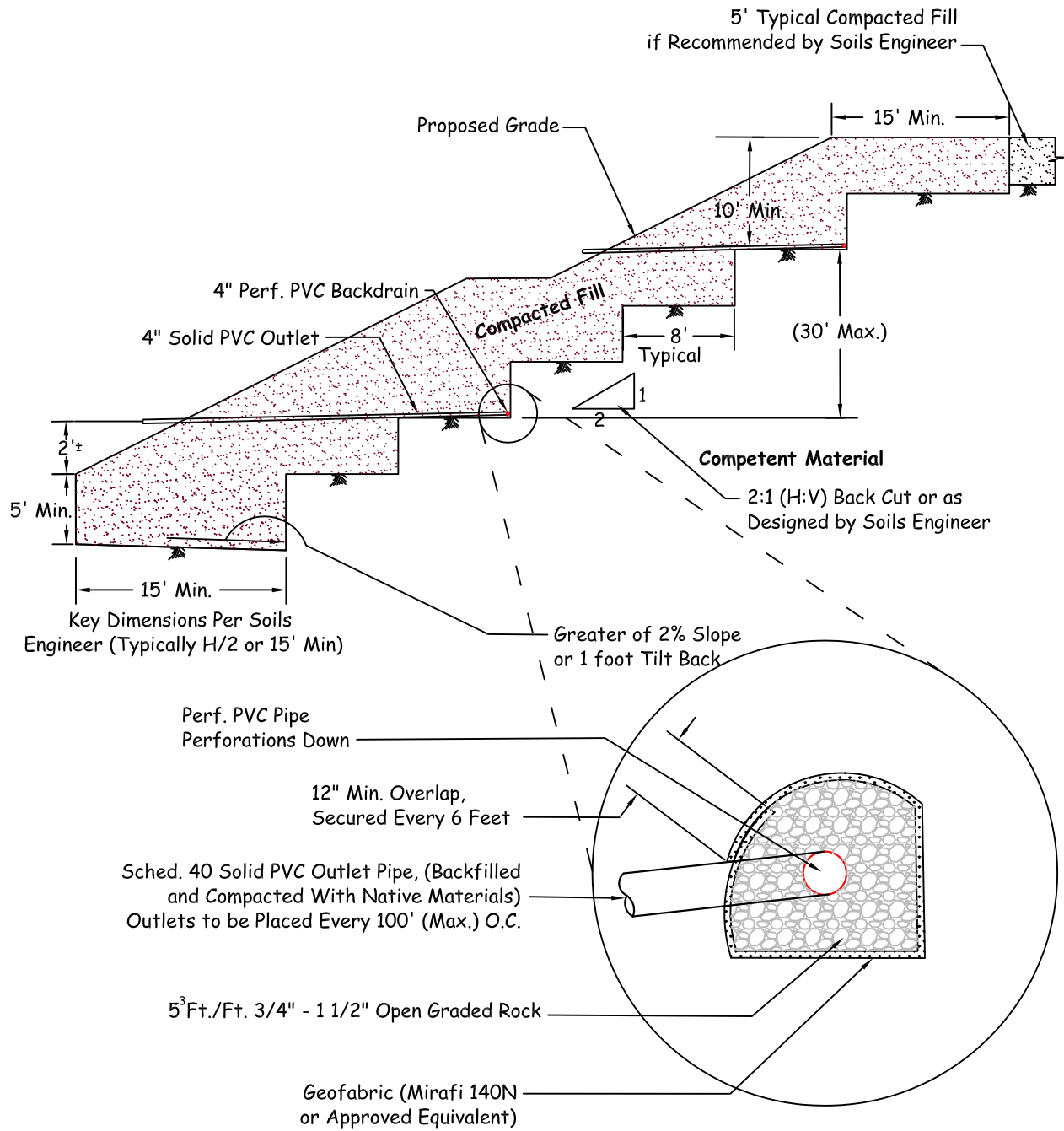

SUBDRAIN OUTLET MARKER -6" & 8" PIPE

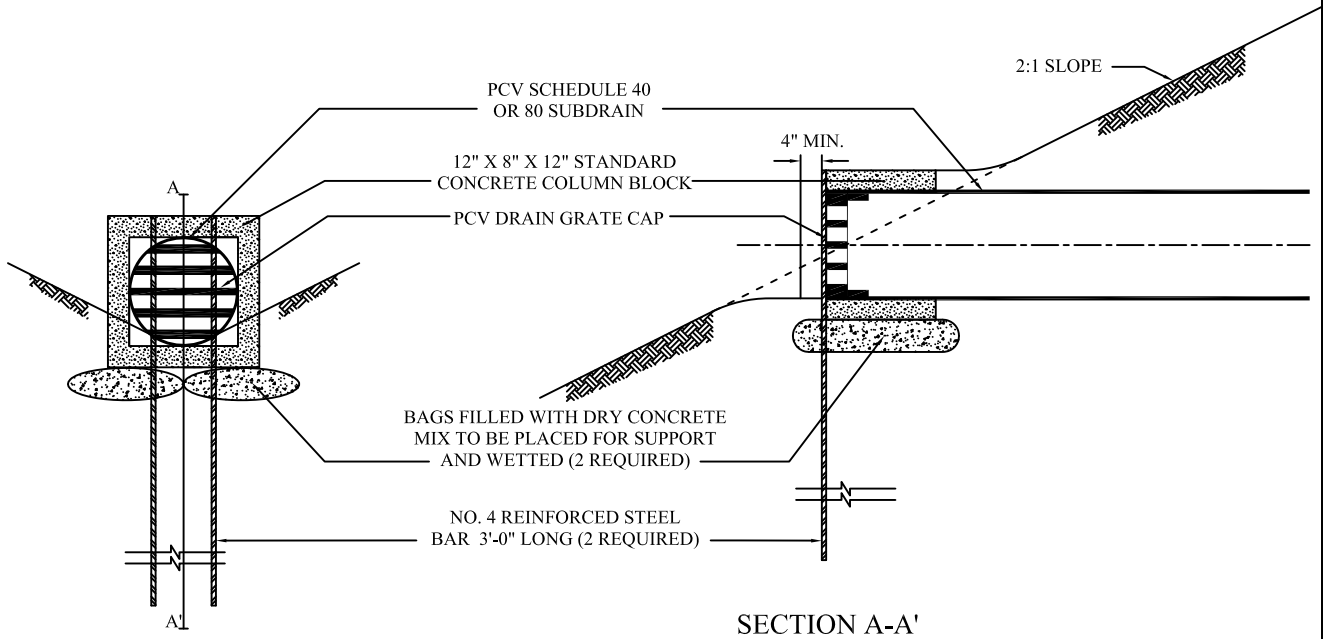

SUBDRAIN OUTLET MARKER -4" PIPE

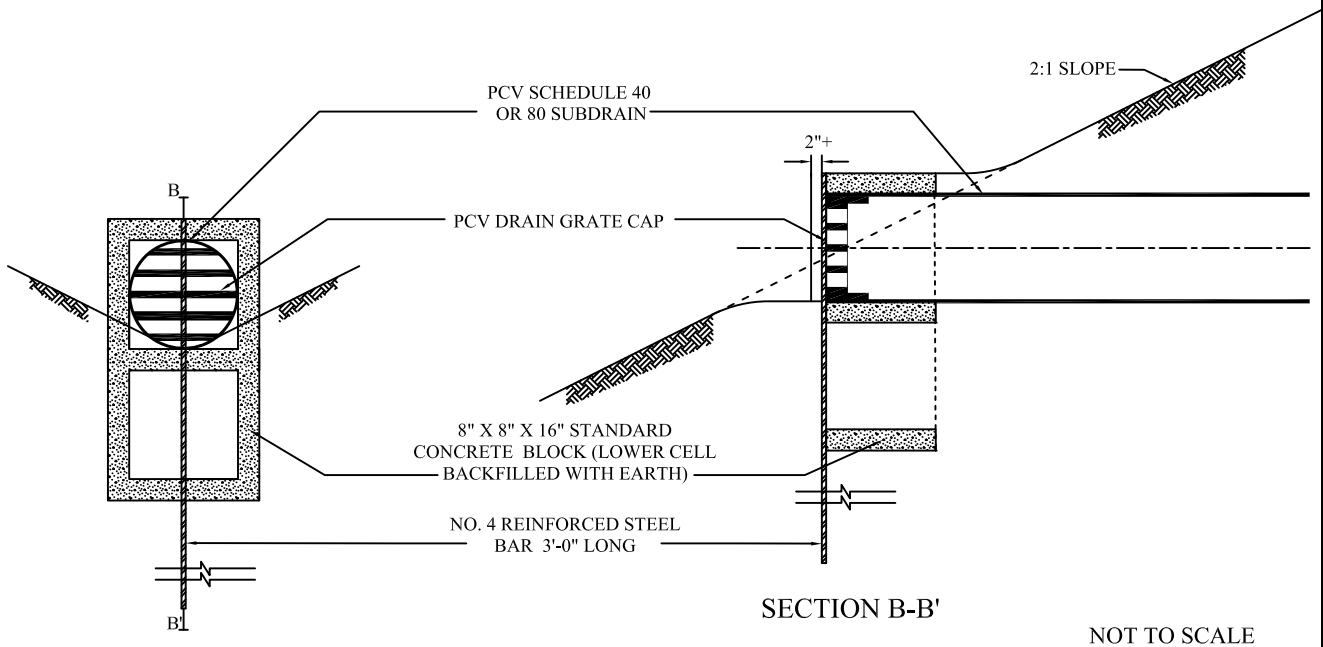

**SUBDRAIN OUTLET
MARKER DETAIL**

Cut Lot (Exposing Unsuitable Soils at Design Grade)

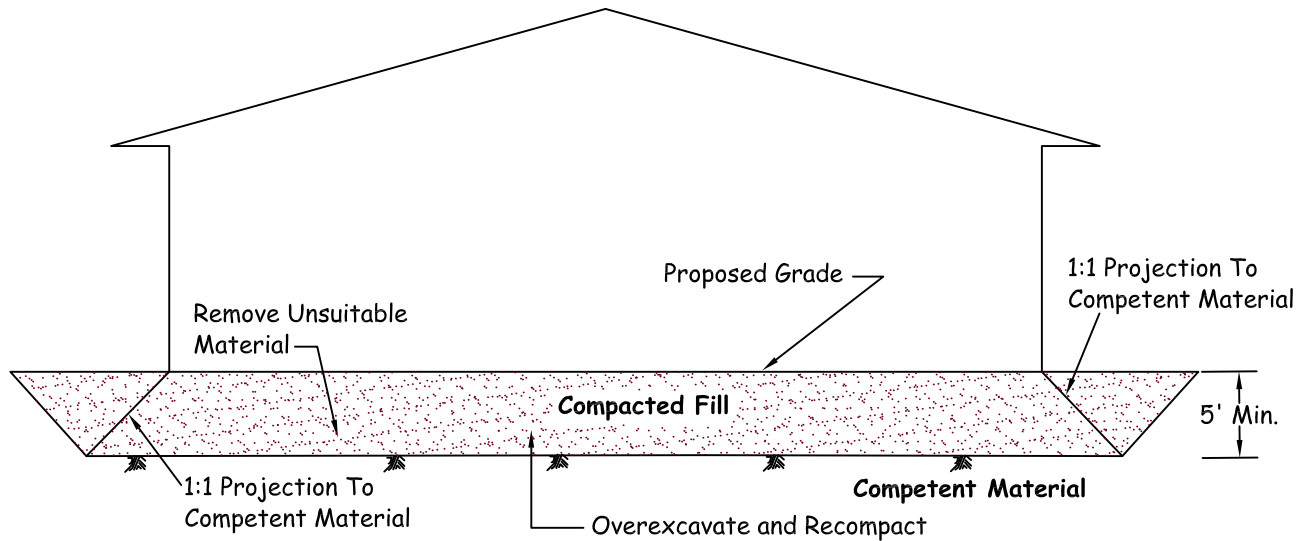

Note 1: Removal Bottom Should be Graded With Minimum 2% Fall Towards Street or Other Suitable Area (as Determined by Soils Engineer) to Avoid Ponding Below Building

Note 2: Where Design Cut Lots are Excavated Entirely Into Competent Material, Overexcavation May Still be Required for Hard-Rock Conditions or for Materials With Variable Expansion Characteristics.

Cut/Fill Transition Lot

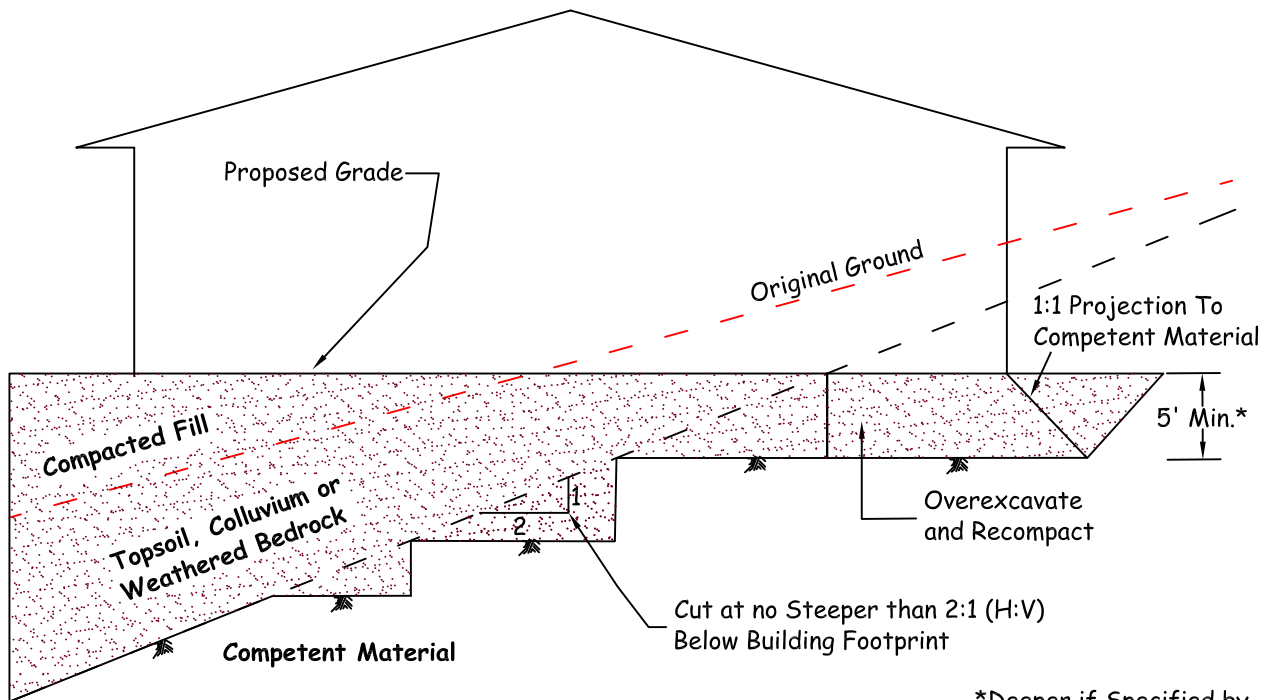

*Deeper if Specified by Soils Engineer



CUT AND TRANSITION LOT OVEREXCAVATION DETAIL

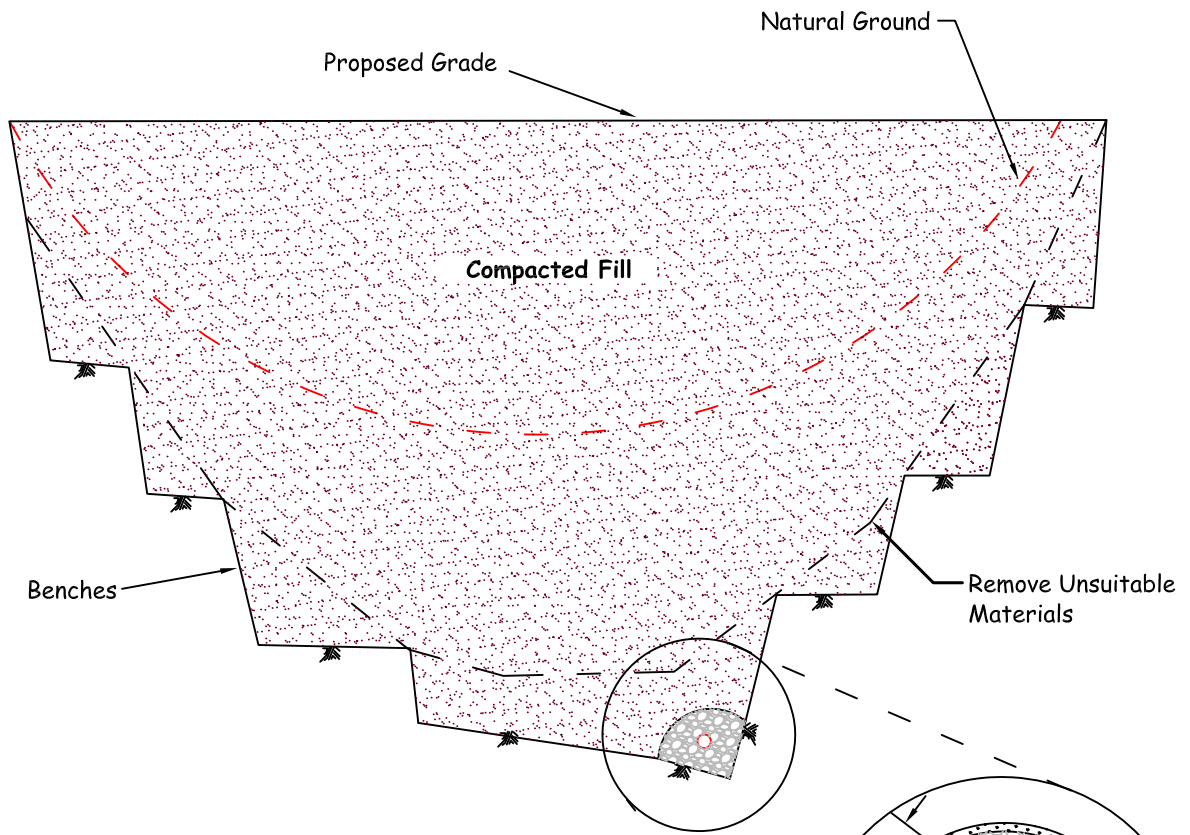

Notes:

- 1) Continuous Runs in Excess of 500' Shall Use 8" Diameter Pipe.
- 2) Final 20' of Pipe at Outlet Shall be Solid and Backfilled with Fine-grained Material.

12" Min. Overlap,
Secured Every 6 Feet

6" Collector Pipe
(Sched. 40, Perf. PVC)

9 Ft.³/Ft.
3/4" - 1 1/2" Crushed Rock

Geofabric (Mirafi 140N
or Approved Equivalent)

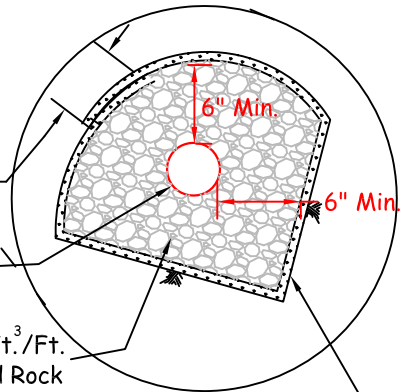

Proposed Outlet Detail

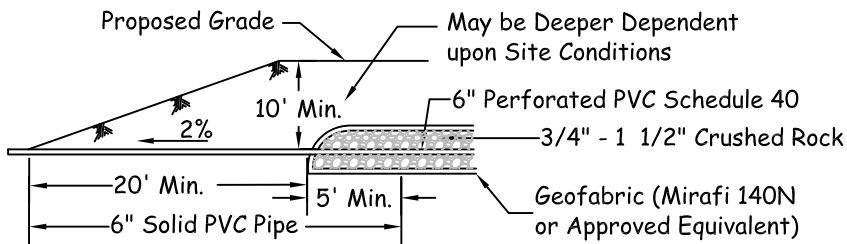

CANYON SUBDRAINS

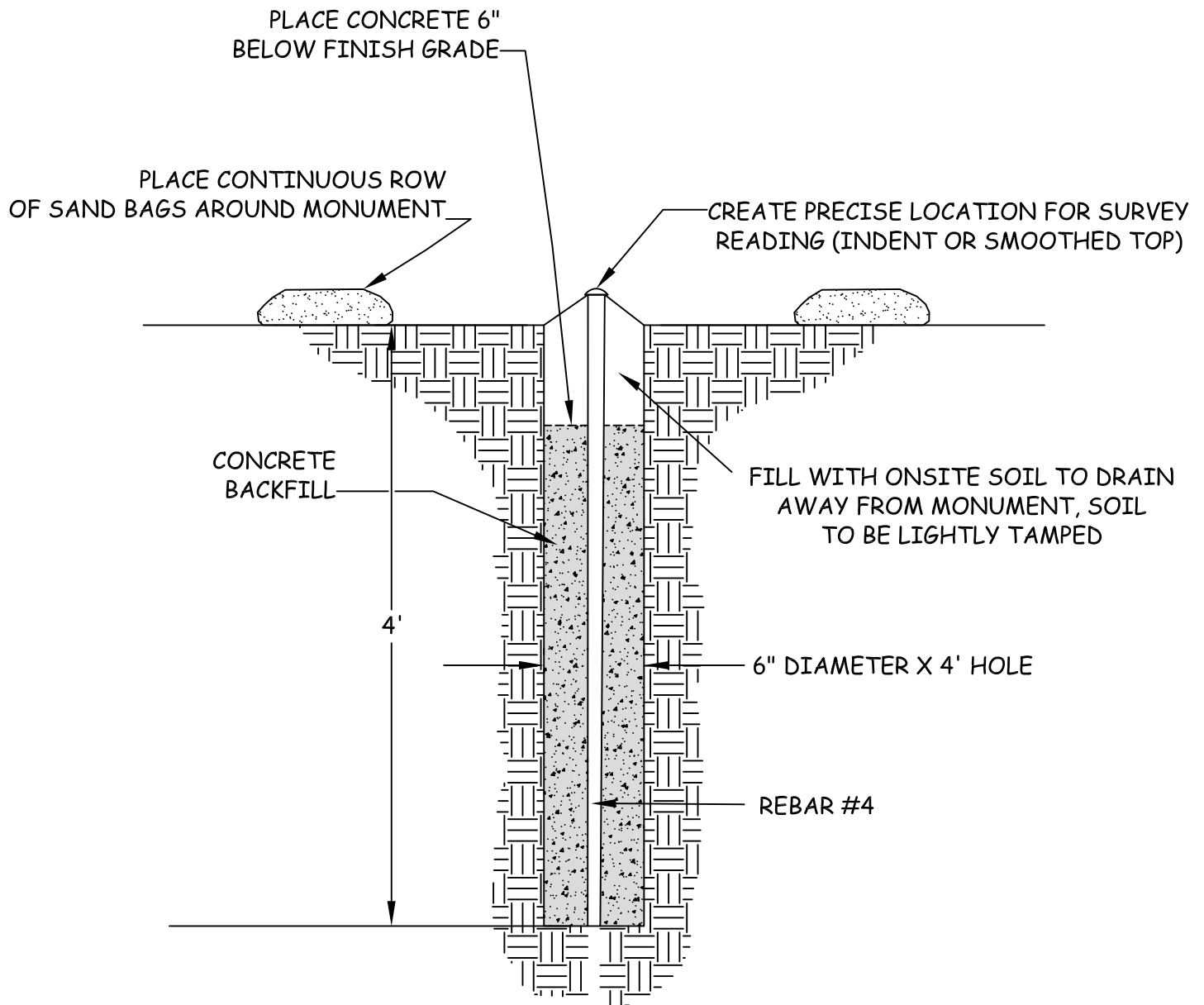

NO CONSTRUCTION EQUIPMENT WITHIN 25 FEET OF ANY INSTALLED SETTLEMENT MONUMENTS



TYPICAL SURFACE SETTLEMENT MONUMENT

TOP VIEW

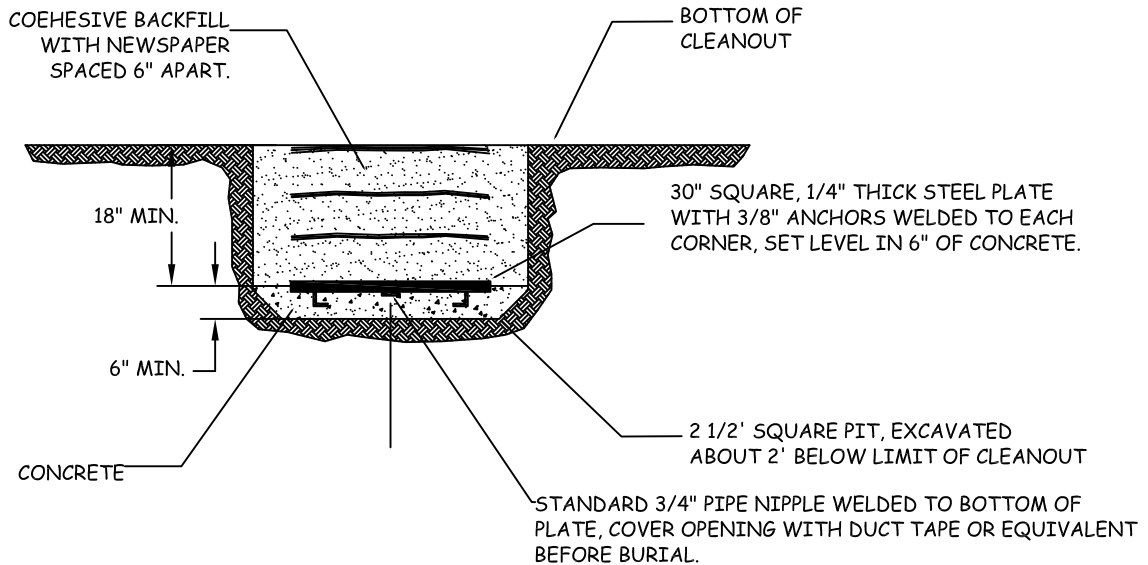
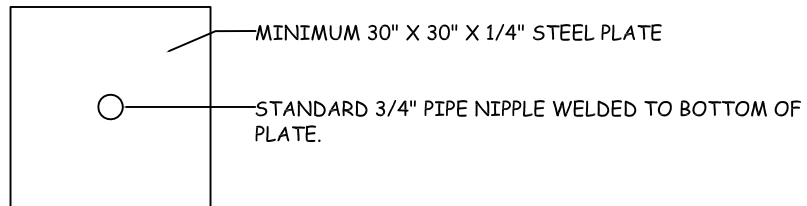

1. SURVEY FOR HORIZONTAL AND VERTICAL LOCATION TO NEAREST .01 INCH PRIOR TO BACKFILL USING KNOW LOCATIONS THAT WILL REMAIN INTACT DURING THE DURATION OF THE MONITORING PROGRAM. KNOW POINTS EXPLICITLY NOT ALLOWED ARE THOSE LOCATED ON FILL OR THAT WILL BE DESTROYED DURING GRADING.
2. IN THE EVENT OF DAMAGE TO SETTLEMENT PLATE DURING GRADING, CONTRACTOR SHALL IMMEDIATELY NOTIFY THE GEOTECHNICAL ENGINEER AND SHALL BE RESPONSIBLE FOR RESTORING THE SETTLEMENT PLATES TO WORKING ORDER.
3. DRILL TO RECOVER AND ATTACH RISER PIPE.



TYPICAL SETTLEMENT PLATE AND RISER

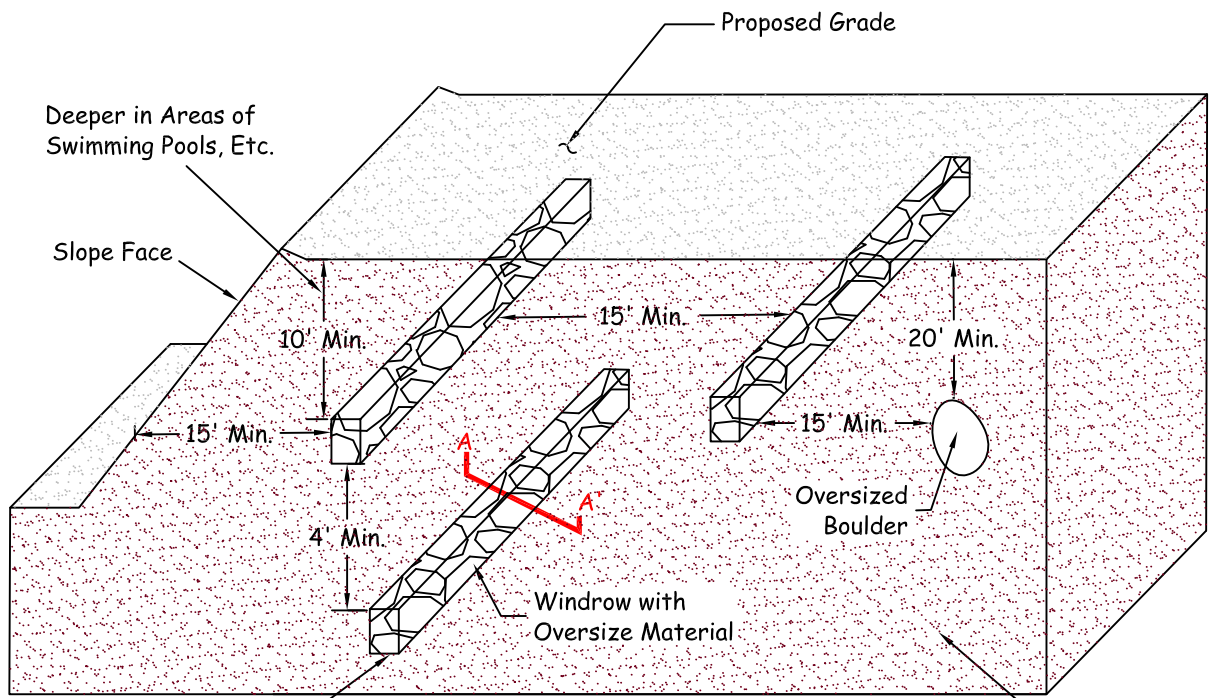

Windrow Parallel to Slope Face

Jetted or Flooded Approved Granular Material

Excavated Trench or Dozer V-cut

Compacted Fill

Note: Oversize Rock is Larger than 8" in Maximum Dimension.

Section A-A'



OVERSIZE ROCK DISPOSAL DETAIL